

G20 Series

Maximum Flow Rate: 1.0 gpm (3.8 l/min)

Maximum Pressure: 1500 psi (103 bar) for Metallic Pump Heads
350 psi (24 bar) for Non-metallic Pump Heads

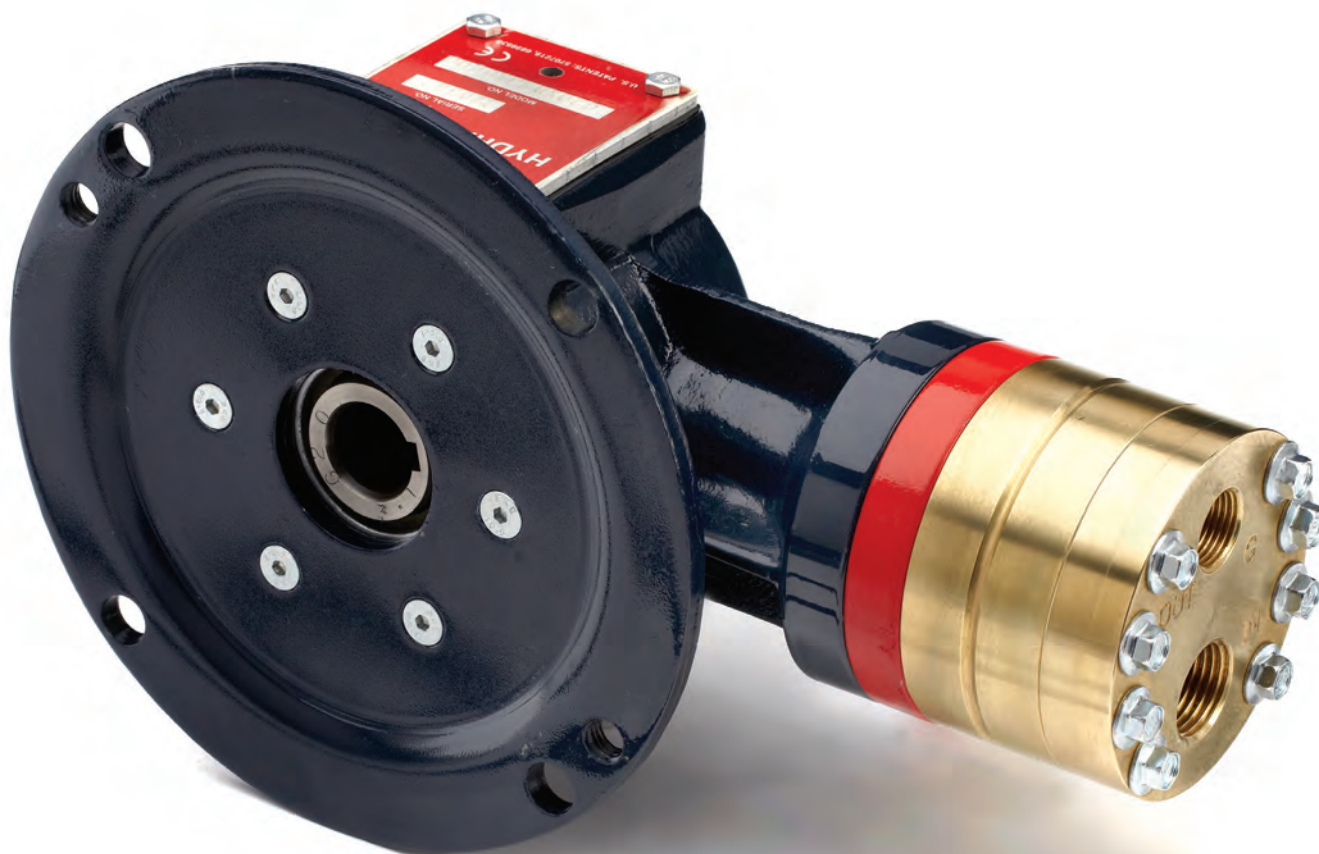

G20 Close-coupled with Brass pump head

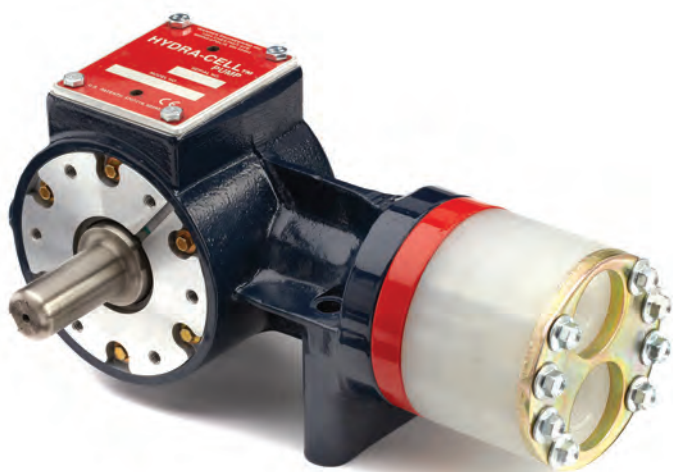

G21 Shaft-driven with Polypropylene pump head



G22 Flexible-coupled with Stainless Steel pump head

G20 Series Performance

Capacities

Flow

Model	Max. Input rpm	Max. Flow @ 1000 psi (69 bar)	
		gpm	l/min
G20-X	1750	1.01	3.82
G20-E	1750	0.71	2.69
G20-S	1750	0.56	2.12
G20-B	1750	0.31	1.17
G20-G	1750	0.20	0.76

Pressure

Maximum Inlet Pressure
250 psi (17 bar)

Maximum Discharge Pressure

Metallic Pump Heads:

G20 to 1000 psi (69 bar)

G21 to 1500 psi (103 bar)

G22 to 1500 psi (103 bar)

Non-metallic Pump Heads:

250 psi (17 bar) Polypropylene

350 psi (24 bar) PVDF

Performance and specification ratings apply to G20, G21 and G22 configurations unless specifically noted otherwise.

Maximum Flow at Designated Pressure

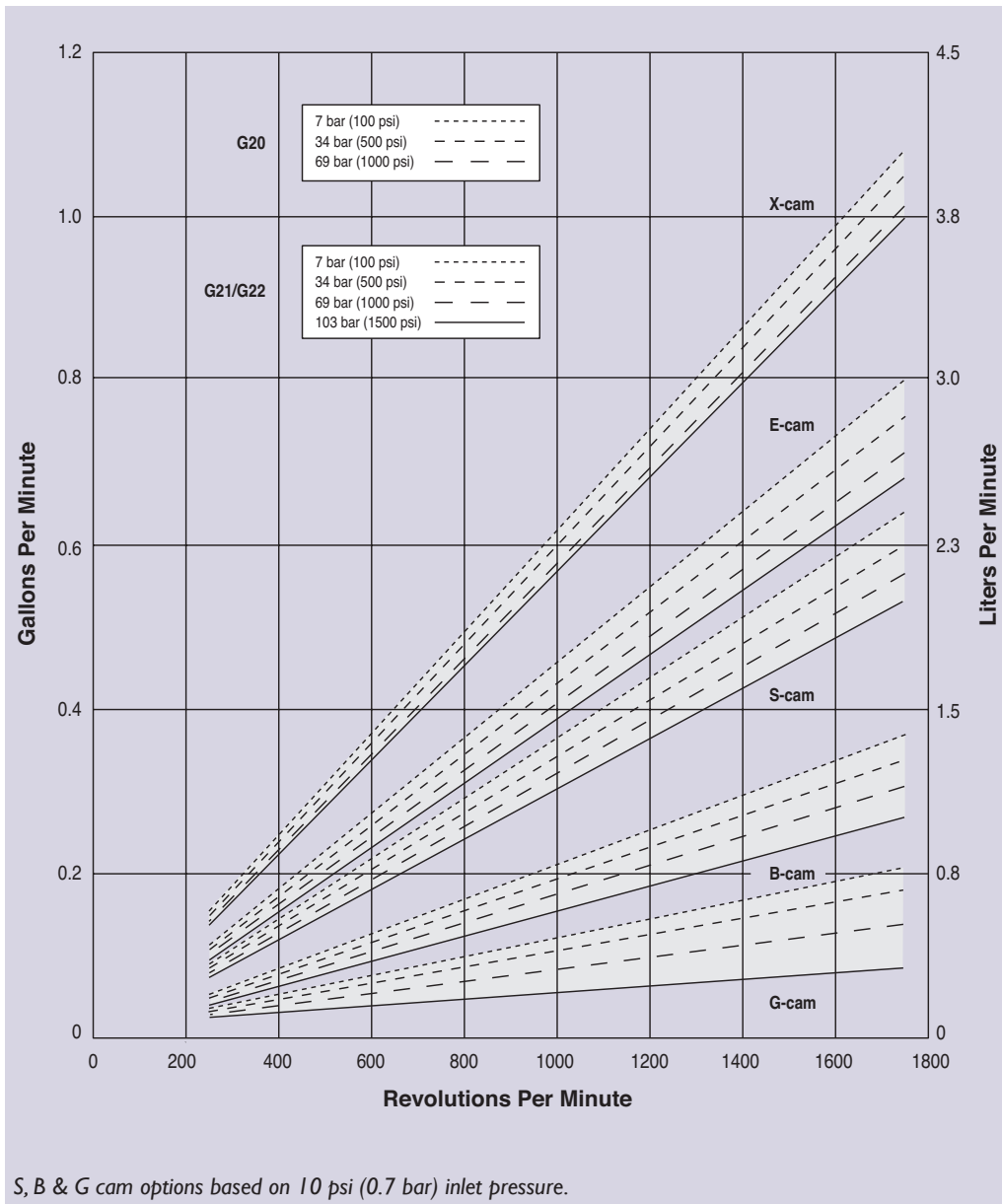

G20 Series Specifications

Flow Capacities @ 69 bar (1000 psi) 4-pole Motor @ 50 Hz

Model	rpm	gpm	l/min
G20-X	1450	0.83	3.14
G20-E	1450	0.60	2.29
G20-S	1450	0.45	1.72
G20-B	1450	0.27	1.03
G20-G	1450	0.16	0.63

Flow Capacities @ 69 bar (1000 psi) 6-pole Motor @ 50 Hz

Model	rpm	gpm	l/min
G20-X	960	0.55	2.08
G20-E	960	0.40	1.51
G20-S	960	0.30	1.14
G20-B	960	0.18	0.68
G20-G	960	0.10	0.41

Delivery @ 69 bar (1000 psi)

Model	gal/rev	liters/rev
G20-X	0.0006	0.0022
G20-E	0.0004	0.0015
G20-S	0.0003	0.0012
G20-B	0.0002	0.0007
G20-G	0.0001	0.0004

Maximum Discharge Pressure

Metallic Heads:	G20 to 69 bar (1000 psi)
	G21 to 103 bar (1500 psi)
	G22 to 103 bar (1500 psi)
Non-metallic Heads:	17 bar (250 psi) Polypropylene
	24 bar (350 psi) PVDF

Maximum Inlet Pressure 17 bar (250 psi)

Maximum Operating Temperature

Metallic Heads:	121 °C (250 °F) - Consult factory for correct component selection for temperatures from 71 °C (160 °F) to 121 °C (250 °F).
Non-metallic Heads:	60 °C (140 °F)

Maximum Solids Size 200 microns

Inlet Port 1/2 inch BSPT

1/2 inch NPT

Discharge Port 3/8 inch BSPT

3/8 inch NPT

Shaft Diameter G20: 19 mm hollow shaft G21 & G22: 19 mm (3/4 inch)

Shaft Rotation Reverse (bi-directional)

Bearings Precision ball bearings

Oil Capacity 0.12 liters (0.125 US quart) - See pages 96 and 97 for oil selection and specification.

Weight

Metallic Heads:	5.5 kg (12 lbs.)
Non-metallic Heads:	4.1 kg (9 lbs.)

Calculating Required Power

$$\frac{\text{rpm} + 1000}{7000} + \frac{\text{gpm} \times \text{psi}}{1,460} = \text{electric motor hp}$$

$$\frac{\text{rpm} + 1000}{9383} + \frac{\text{l/min} \times \text{bar}}{511} = \text{electric motor kW}$$

See page 164 for calculating pulley size.

When using a variable frequency drive (VFD) calculate the hp or kW at minimum and maximum pump speed to ensure the correct hp or kW motor is selected. Note that motor manufacturers typically de-rate the service factor to 1.0 when operating with a VFD.

Net Positive Suction Head (NPSHr)

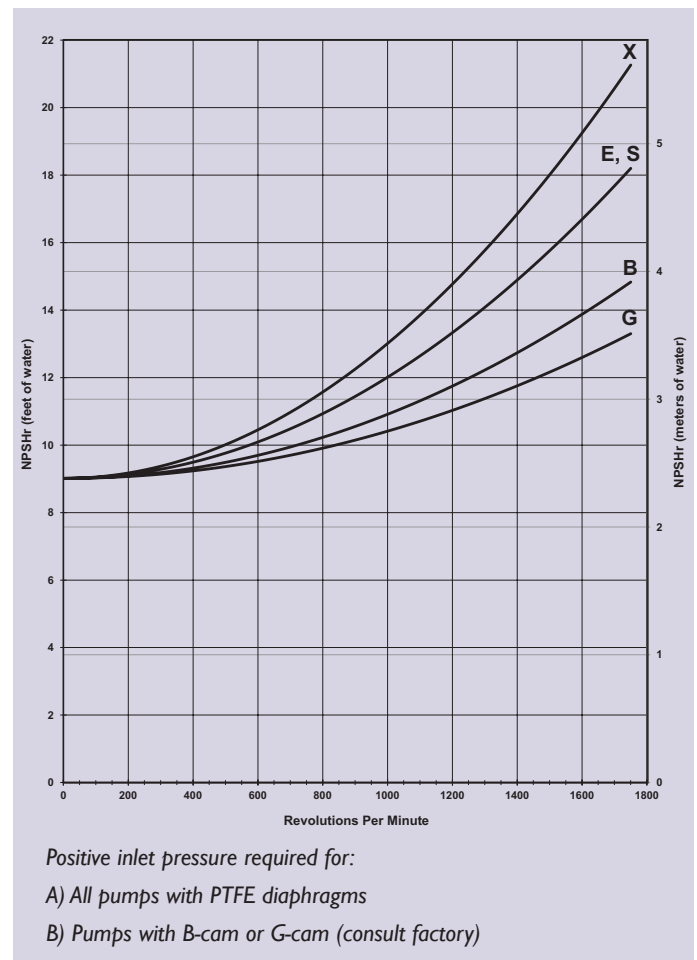

Self-priming:

Each Hydra-Cell pump has different lift capability depending on model size, cam angle, speed, and fluid characteristics. To ensure that your specific lift characteristics are met, refer to the inlet calculations regarding friction, and acceleration head losses in your Hydra-Cell Installation & Service Manual. Compare those calculations to the NPSHr curves above.

For technical assistance in pump selection, see Frequently Asked Questions on page 162, Design Considerations on page 163, and Installation Guidelines on pages 164-165.

G20 Series Representative Drawings

G20 Models with Metallic Pump Head mm (Inches)

* Add 6.35mm (0.25") where shown for manifold cover plate on non-metallic models.

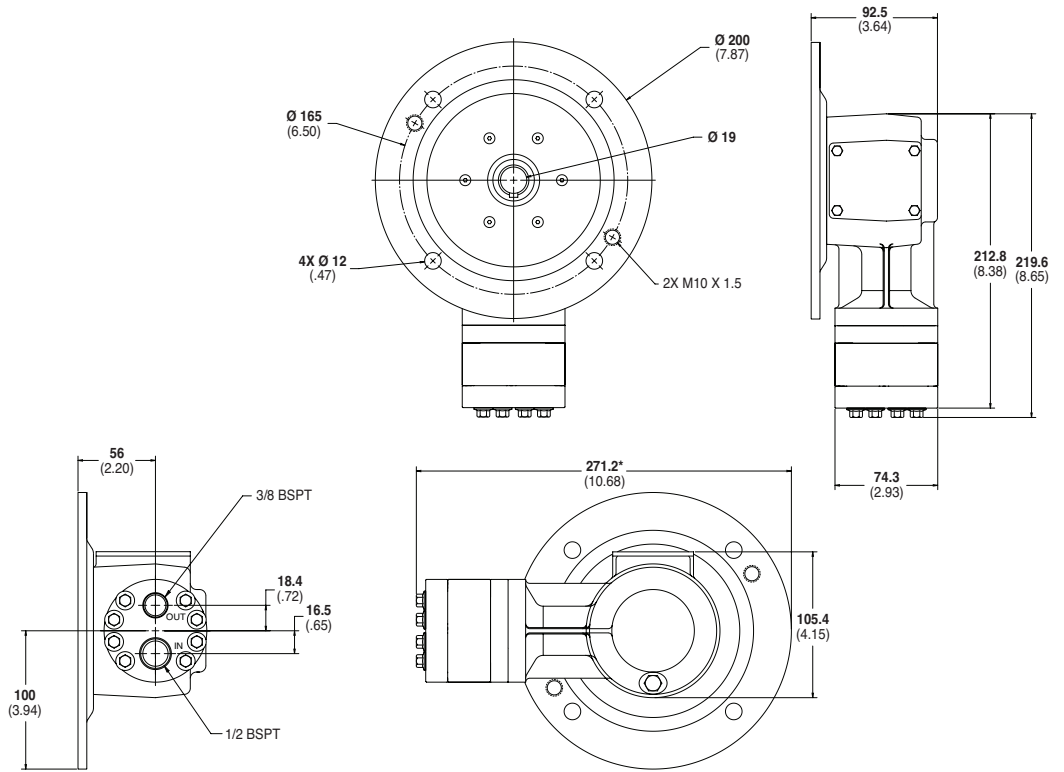

G21 Models with Metallic Pump Head mm (Inches)

* Add 6.35mm (0.25") where shown for manifold cover plate on non-metallic models.

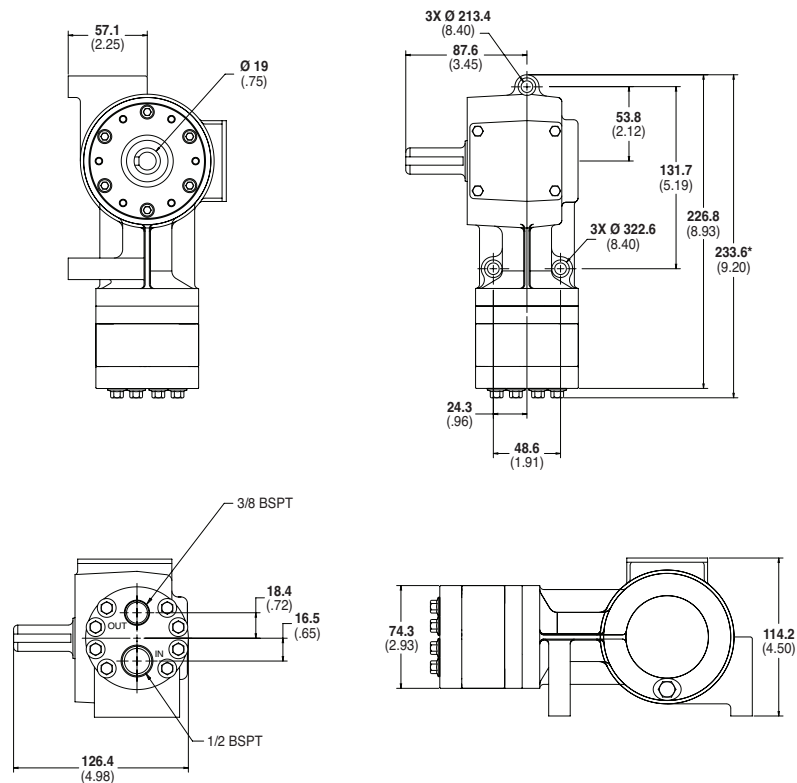

Note: Contact factory for additional drawings of specific models and configurations.

G20 Series Drawings/Adapters/Valves

G22 Models with Metallic Pump Head mm (Inches)

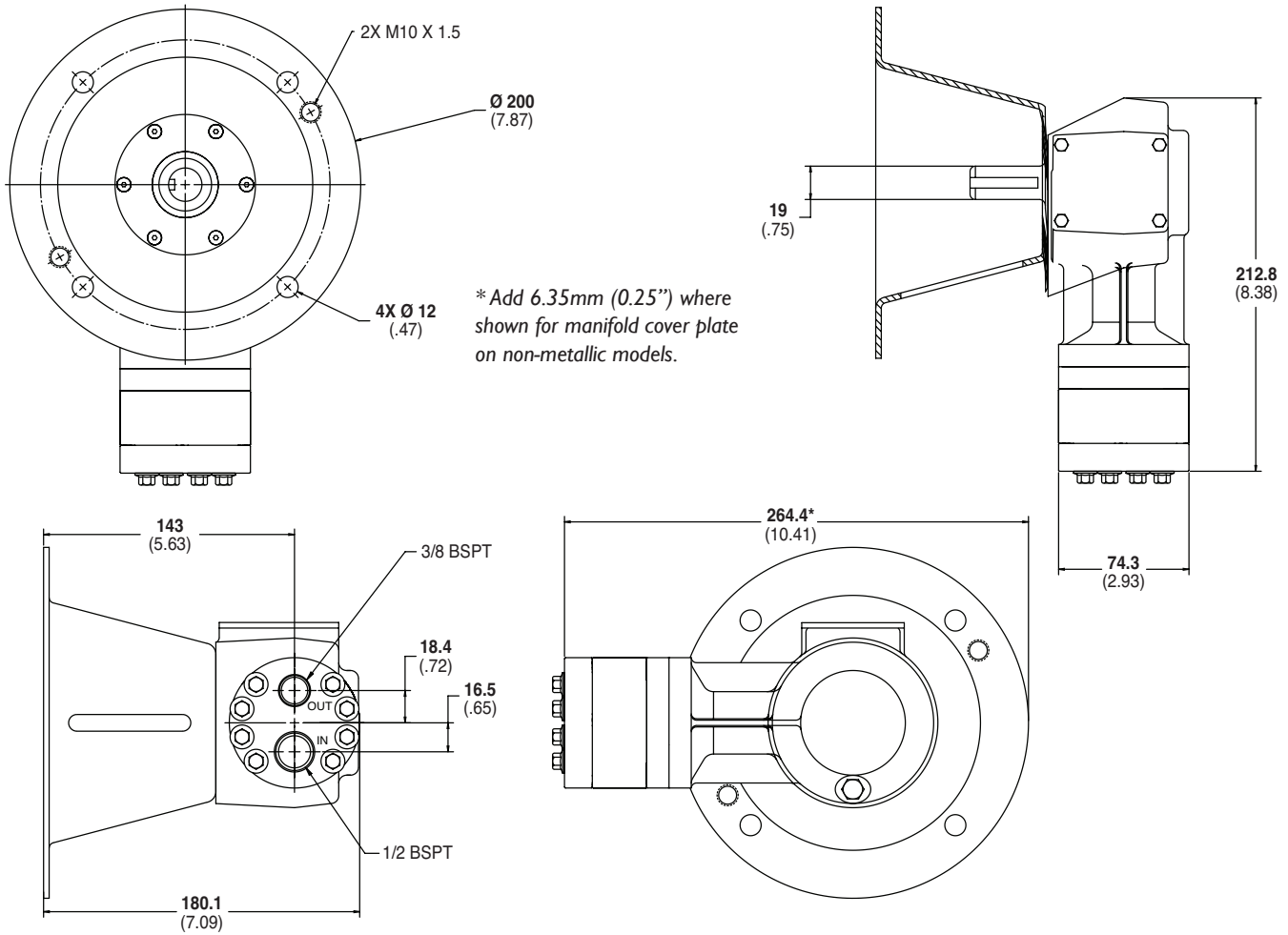

Note: Contact factory for additional drawings of specific models and configurations.

Pump/Motor Adapter Inches (mm)

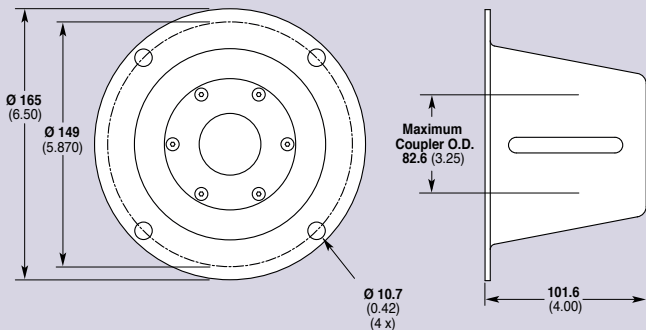

Part Number: A04-006-1200

Must be ordered separately for G22 models (optional for G21 models) for use with IEC 80 - 90 frame motors, B5 flange.

NEMA adapter available - consult factory.

Valve Selection

A Hydra-Cell G20, G21 or G22 pumping system uses a C46 Pressure Regulating Valve.

See page 86 for more information.



G20 Series How to Order

Ordering Information



A complete G20 Series Model Number contains 12 digits including 9 customer-specified design and materials options, for example: G20GAPGHFECCG.

Digit	Order Code	Description
1-3		Pump Configuration
	G20	Close-coupled to IEC 80 footed motor (BSPT Ports)
	G21	Shaft-driven (BSPT Ports)*
	G22	For use with pump/motor adapter (BSPT Ports)* *Pump/motor adapters ordered separately. See previous page.
4		Hydraulic End Cam
	X	Max 3.1 l/min (0.8 gpm) @ 1450 rpm
	E	Max 2.3 l/min (0.6 gpm) @ 1450 rpm
	S	Max 1.7 l/min (0.4 gpm) @ 1450 rpm
	B	Max 1.0 l/min (0.3 gpm) @ 1450 rpm
	G	Max 0.6 l/min (0.2 gpm) @ 1450 rpm
5		Pump Head Version
	D	BSPT Ports (for all G20, G21 & G22 pumps)
	X	ATEX <i>(Note: ATEX 94/9/EC Certified, Category 2, Zone 1. Includes certificate and oil level monitor.)</i>
6		Pump Head Material
	B	Brass
	M	PVDF
	P	Polypropylene
	S	316L Stainless Steel
	T	Hastelloy C
7		Diaphragm & O-ring Material
	A	Aflas diaphragm/PTFE o-ring
	E	EPDM (requires EPDM-compatible oil - Digit 12 oil code J)
	G	FKM
	J	PTFE (available with X and E cams only)
	P	Neoprene
	T	Buna-N
8		Valve Seat Material
	C	Ceramic
	D	Tungsten Carbide
	H	17-4 Stainless Steel
	S	316L Stainless Steel
	T	Hastelloy C

Digit	Order Code	Description
9		Valve Material
	C	Ceramic
	D	Tungsten Carbide
	F	17-4 Stainless Steel
	N	Nitronic 50
	T	Hastelloy C
10		Valve Springs
	E	Elgiloy
	T	Hastelloy C
11		Valve Spring Retainers
	C	Celcon
	H	17-7 Stainless Steel
	M	PVDF
	P	Polypropylene
	T	Hastelloy C
	Y	Nylon
12		Hydra-Oil
	G	5W30 cold-temp severe-duty synthetic oil
	J	EPDM-compatible oil
	K	Food-contact oil

Note: For motors, bases, couplings and other pump accessories, refer to the Accessories section beginning on page 92.

Hydra-Cell®

Seal-less Pumps

Wanner Engineering, Inc.

World Headquarters & Manufacturing

Wanner Engineering, Inc.
1204 Chestnut Avenue,
Minneapolis, MN 55403 USA
Phone: 612-332-5681 • Fax: 612-332-6937
Toll-Free Fax (USA): 800-332-6812
Email: sales@wannereng.com
www.Hydra-Cell.com

Regional Office

207 US Highway 281
Wichita Falls, TX 76310 USA
Phone: 940-322-7111
Toll-Free: 800-234-1384
Email: sales@wannereng.com
www.Hydra-Cell.com

Latin American Office

R. Álvaro Anes, 150 Bairro Campestre
Santo André/São Paulo, Brazil - CEP 09070-030
Phone: +55 (11) 4081-7098
Email: mmagoni@wannereng.com
www.Hydra-Cell.com

Wanner International Ltd.

Wanner International, Ltd.
Hampshire - United Kingdom
Phone: +44 (0) 1252 816847
Email: sales@wannerint.com
www.Hydra-Cell.eu

Wanner Pumps Ltd.

Wanner Pumps, Ltd.
Kowloon - Hong Kong
Phone: +852 3428 6534
Email: sales@wannerpumps.com
www.WannerPumps.com

Shanghai - China
Phone: +86-21-6876 3700
Email: sales@wannerpumps.com
www.WannerPumps.com

