

P100 PRO SERIES METERING PUMPS

Maximum Flow Rate: 27.0 gph (85.0 lph)
Maximum Pressure: 1500 psi (103 bar) for Metallic Pump Heads
350 psi (24 bar) for Non-metallic Pump Heads

 **WANNER™** HYDRA-CELL® PRO
METERING PUMP SOLUTIONS



Hydra-Cell Pro Metering Solutions pumps meet or exceed API 675 performance standards for Steady-State Accuracy ($\pm 1\%$), Linearity ($\pm 3\%$), and Repeatability ($\pm 3\%$).

UK
CA CE

P100 with Brass pump head

Metering Pump with “Pulse-Free” Linear Flow*

- Handles a wide range of fluids from clear water to thick slurries
- Electronic flow control increases accuracy and reliability
- Smaller footprint saves valuable space
- One pump covers a wide range of flows and pressures – reducing inventory requirements with fast, simple field conversion
- Duplexing option doubles capacity and equipment savings
- Hydraulically-actuated, balanced diaphragms provide superior performance across entire pressure range
- Rugged construction with a variety of affordable choices for liquid end, diaphragm and check valve materials
- Seal-less design means no seals, cups, or packing to leak or replace
- A replenishment valve in every piston assembly ensures optimum actuating oil on every stroke for continuous accuracy

**See Note on Page 3*

P100 Pro Series Metering | Performance

Performance

Flows shown are for pumps with elastomeric diaphragms (consult factory for performance characteristics of pumps with PTFE diaphragms) and are based upon lab testing of multiple pumps. However, flows listed are approximate values and pumps must be calibrated once installed into any system. Flow variations will occur, but calibration will ensure proper pump performance.

Maximum Flow (gph) at Designated Pressure (psi)

All Pumps (gph)		Metallic Pump Heads Only (gph)			Pump rpm	Gear Ratio	Motor rpm
100 psi	250 psi	500 psi	1000 psi	1500 psi			
1.086	1.077	1.058	1.015	0.981	30	60:1	1800
1.316	1.300	1.273	1.220	1.184	36	50:1	
1.630	1.628	1.607	1.535	1.492	45	40:1	
2.192	2.182	2.148	2.056	2.000	60	30:1	
2.643	2.626	2.582	2.473	2.405	72	25:1	
3.318	3.291	3.232	3.099	3.014	90	20:1	
4.444	4.400	4.316	4.141	4.028	120	15:1	
6.695	6.618	6.483	6.226	6.057	180	10:1	
8.947	8.836	8.651	8.311	8.085	240	7.5:1	
13.45	13.27	12.99	12.48	12.14	360	5:1	
17.95	17.71	17.32	16.65	16.20	480	7.5:1	3600
26.96	26.58	25.99	24.99	24.31	720	5:1	

Required Motor hp

1/2	3/4	1
-----	-----	---

Maximum Flow (lph) at Designated Pressure (bar)

All Pumps (lph)		Metallic Pump Heads Only (lph)			Pump rpm	Gear Ratio	Motor rpm
7 bar	17 bar	34 bar	69 bar	103 bar			
3.425	3.396	3.337	3.203	3.095	25	60:1	1500
4.150	4.102	4.016	3.850	3.735	30	50:1	
5.140	5.135	5.068	4.841	4.708	37.5	40:1	
6.916	6.884	6.777	6.486	6.307	50	30:1	
8.336	8.283	8.145	7.801	7.587	60	25:1	
10.47	10.38	10.20	9.774	9.507	75	20:1	
14.02	13.88	13.61	13.06	12.71	100	15:1	
21.12	20.88	20.45	19.64	19.11	150	10:1	
28.22	27.87	27.29	26.22	25.50	200	7.5:1	
42.43	41.87	40.96	39.37	38.30	300	5:1	
56.63	55.86	54.64	52.53	51.10	400	7.5:1	3000
85.04	83.85	81.98	78.84	76.70	600	5:1	

Required Motor kW

0.18	0.25	0.37	0.55
------	------	------	------

Due to the Wanner Engineering Continuous Improvement Program, specifications and other data are subject to change.

P100 Pro Series Metering | Performance

Pump Data

Diaphragms per Liquid End	1
Flow Control	Electronic variable speed drive
Maximum Discharge Pressure	
Metallic Heads:	1500 psi (103 bar)
Non-metallic Heads:	PVDF – 350 psi (24 bar) Polypropylene – 250 psi (17 bar)
Maximum Inlet Pressure	250 psi (17 bar)
Maximum Operating Temperatures	
Metallic Heads:	250°F (121°C)
Non-metallic Heads:	140°F (60°C)
	<i>Consult factory for correct metallic head component selection for temperatures from 160°F (71°C) to 250°F (121°C).</i>
Maximum Solids Size	200 microns
Inlet Port	1/2 inch NPT or BSPT
Discharge Port	3/8 inch NPT or BSPT
Shaft Rotation	Bi-directional
Oil Capacity	0.125 US quarts (0.12 liters)
Weight (less motor)	
Metallic Heads:	21.3 lbs. (9.7 kg)
Non-metallic Heads:	19.2 lbs. (8.7 kg)
Dimensions (less motor)	
Metallic Heads:	9.93" W x 11.36" D x 6.92" H (252.2 mm W x 287.4 mm D x 175.8 mm H)
Non-metallic Heads:	9.93" W x 11.61" D x 6.92" H (252.2 mm W x 294.9 mm D x 175.8 mm H)
	<i>For NEMA 56 motor frames only; see page 6 for other motor frame sizes.</i>

Accessories, Options and Services

Consult Wanner Engineering for complete details about available accessories and options as well as special services.

- Manifolds and Flanges
- Multiplexing Capability
- Different Gearbox Ratios
- Oil Cooler Systems
- Actuating Oils
- Magnetic Drain Plug
- Motors (Standard/Hazardous-duty)
- Controllers
- Control Freak™ Touch-screen Metering Controller
- SmartDrive Motor-Controller
- Calibration Cylinders
- Back Pressure Valves
- Pressure Relief Valves
- Pulsation Dampeners
- Demonstration (Cutaway) Units
- Testing Services
- System Components, Priming Kits and Plugs
- Replacement Part Kits and Tool Kits
- Customization Services

**Note: Since the P100 is the only single-diaphragm pump model in the Hydra-Cell Metering Solutions P Series line, it is recommended that pulsation dampeners be used to achieve virtually pulse-free flow.*



P100 with Stainless Steel pump head



P100 with Polypropylene pump head

Due to the Wanner Engineering Continuous Improvement Program, specifications and other data are subject to change.

P100 Pro Series Metering | Representative Drawings

Metallic and Non-metallic Pump Heads Inches (mm)

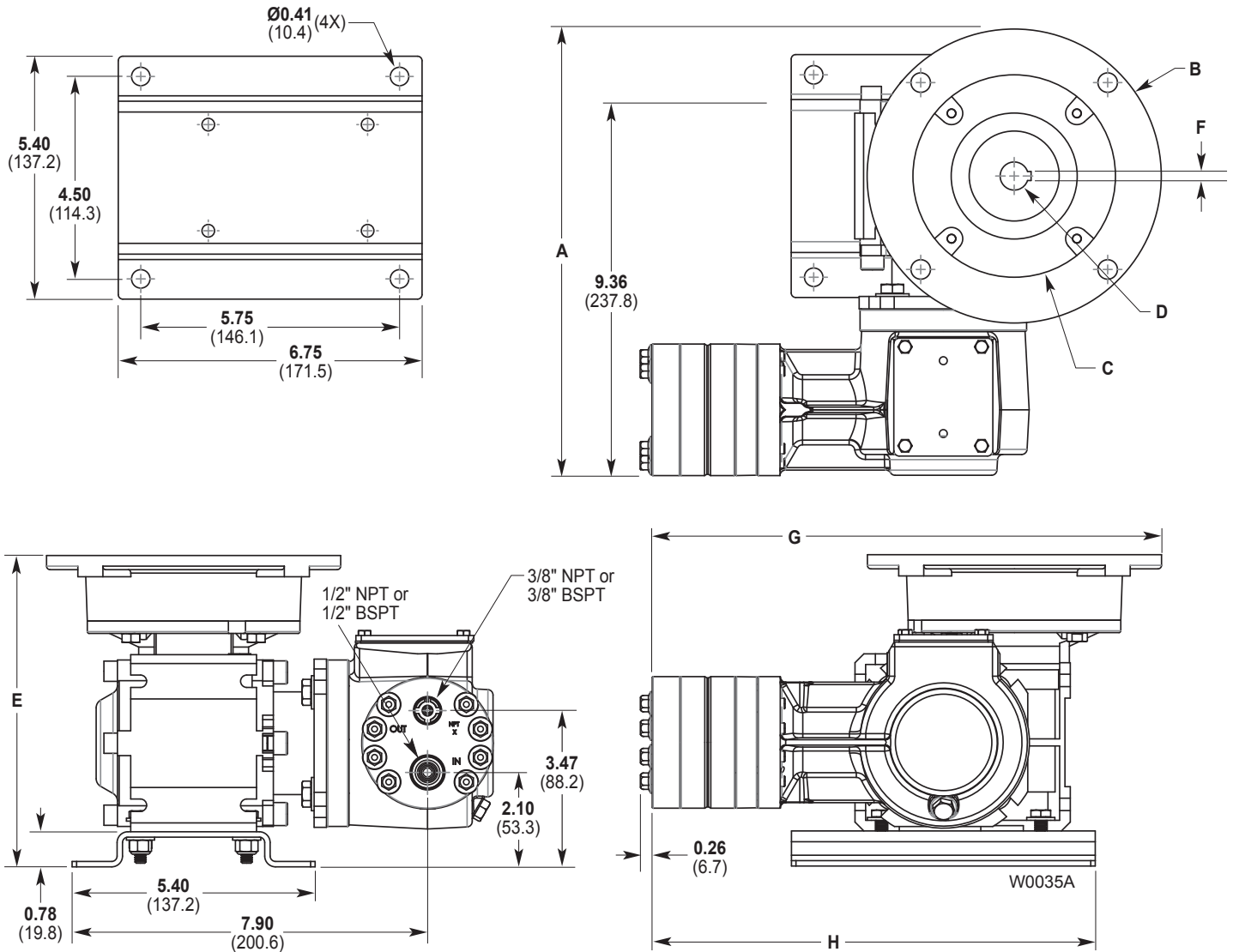

Note: Dimensions are for reference only. Contact factory for certified drawings.

Dimensions: Inches (mm)

Input Frame Size	A	B	C	D	E	F (Square Key)	G		H	
							Metallic Pump Head	Plastic Pump Head	Metallic Pump Head	Plastic Pump Head
NEMA 56C	9.93 (252.2)	$\text{Ø} 6.54$ ($\text{Ø} 166$)	$\text{Ø} 4.50$ ($\text{Ø} 114.3$)	$\text{Ø} .62$ ($\text{Ø} 15.7$)	6.92 (175.8)	0.187 (4.75)	11.32 (287.5)	11.61 (294.9)	9.84 (250)	10.09 (256.3)
IEC 63 B5	9.42 (239)	$\text{Ø} 5.51$ ($\text{Ø} 140$)	$\text{Ø} 3.74$ ($\text{Ø} 95$)	$\text{Ø} .43$ ($\text{Ø} 11$)	6.74 (171.3)	0.157 (4)	10.80 (274.3)	11.09 (281.7)	9.84 (250)	10.09 (256.3)
IEC 71 B5	9.81 (249.2)	$\text{Ø} 6.30$ ($\text{Ø} 160$)	$\text{Ø} 4.33$ ($\text{Ø} 110$)	$\text{Ø} .55$ ($\text{Ø} 14$)	6.74 (171.3)	0.196 (5)	11.20 (284.5)	11.49 (291.8)	9.84 (250)	10.09 (256.3)
IEC 80 B5	10.59 (260)	$\text{Ø} 7.87$ ($\text{Ø} 200$)	$\text{Ø} 5.12$ ($\text{Ø} 130$)	$\text{Ø} .75$ ($\text{Ø} 19$)	6.74 (171.3)	0.237 (6)	11.98 (304.29)	12.27 (311.6)	9.84 (250)	10.09 (256.3)

P100 Pro Series Metering | How to Order

Ordering Information

A complete pump order number contains 13 digits based on the specified pump materials listed below.

1	2	3	4	5	6	7	8	9	10	11	12	13
P	1	0	0									

Digit	Order Code	Description
1-4	P100	Pump Configuration For all P100 Pumps (Non Kel-Cell)
5	N M X	Pump Version NPT Ports (NEMA motors only) BSPT Ports (IEC motors only) ATEX BSPT Ports (IEC motors only)
6	B M P S T	Pump Head / Retainer Material Brass / Hastelloy C PVDF / PVDF Polypropylene / Polypropylene 316L Stainless Steel / Hastelloy C Hastelloy C / Hastelloy C
7	A E X J P T	Diaphragm & O-ring Material / Oil[▲] Aflas / PTFE O-ring (Synthetic oil) EPDM (EPDM-compatible oil) FKM (Synthetic oil) PTFE (Food-contact oil) <i>(Note: PTFE diaphragms require a minimum suction pressure of 15 psi/1 bar)</i> Neoprene (Synthetic oil) Buna-N (Synthetic oil)

[▲] See price list for different actuating oils available with these materials.

8-9	SS TT SC TC	Check Valve Material (Valve Spring / Valve Seat / Valve) Elgiloy / 316L SST / Nitronic 50 Hastelloy C / Hastelloy C / Hastelloy C Elgiloy / Ceramic / Ceramic Hastelloy C / Ceramic / Ceramic
10-12	060 050 040 030 025 020 015 010 007 005 A05	Gearbox Ratio / NEMA Motors 60:1 (56C Motor Frame) 50:1 (56C Motor Frame) 40:1 (56C Motor Frame) 30:1 (56C Motor Frame) 25:1 (56C Motor Frame) 20:1 (56C Motor Frame) 15:1 (56C Motor Frame) 10:1 (56C Motor Frame) 7.5:1 (56C Motor Frame) 5:1 (56C Motor Frame) 5:1 (143/145TC Motor Frame)

Digit	Order Code	Description
10-12	060 050 A40 030 A30 A25 A20 A15 A10 A07 B07 A05 B05	Gearbox Ratio / IEC Motors 60:1 (63 B5 Motor Frame) 50:1 (63 B5 Motor Frame) 40:1 (71 B5 Motor Frame) 30:1 (63 B5 Motor Frame) 30:1 (71 B5 Motor Frame) 25:1 (71 B5 Motor Frame) 20:1 (71 B5 Motor Frame) 15:1 (71 B5 Motor Frame) 10:1 (71 B5 Motor Frame) 7.5:1 (71 B5 Motor Frame) 7.5:1 (80 B5 Motor Frame) 5:1 (71 B5 Motor Frame) 5:1 (80 B5 Motor Frame)
13	C S	Base Plate Carbon Steel (Epoxy painted) 304 Stainless Steel

Partners in over 70 countries

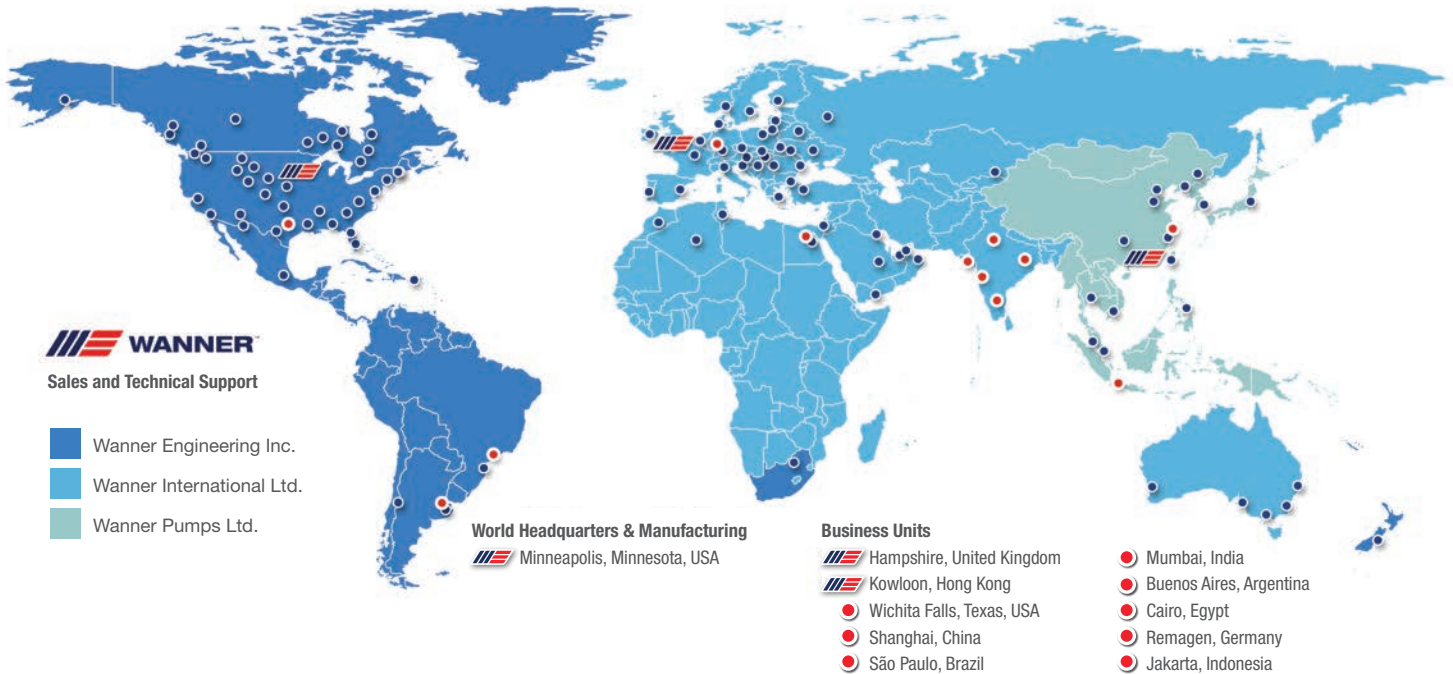

Wanner worldwide

GLOBAL SALES & TECHNICAL SUPPORT

WANNER ENGINEERING, INC.™

WORLD HEADQUARTERS & MANUFACTURING

Minneapolis, Minnesota USA
t: 612-332-5681
e: sales@wannereng.com
Hydra-Cell.com

REGIONAL OFFICE

Wichita Falls, Texas USA
t: 940-322-7111
e: sales@wannereng.com

LATIN AMERICAN OFFICE

São Paulo, Brazil
t: +55 (11) 99582-1969
e: mmagoni@wannereng.com
Hydra-Cell-Pumps.com.br

WANNER INTERNATIONAL, LTD.™

UNITED KINGDOM

8 & 9 Fleet Business Park
Sandy Lane • Church Crookham
Hampshire UK GU52 8BF

t: +44 (0) 1252 816847
e: support@wannerint.com
Hydra-Cell.co.uk

WANNER PUMPS, LTD.™

Kowloon, HONG KONG

t: +852 3428 6534
e: sales@wannerpumps.com
WannerPumps.com

Shanghai, CHINA

t: +86-21-6876 3700
e: sales@wannerpumps.com
WannerPumps.com

