

C SERIES | PRESSURE REGULATING VALVES

Designed for Wanner Hydra-Cell® or any Positive Displacement Pump



Economical C20 Series Valves



In-line and Off-line C46 Series Valves

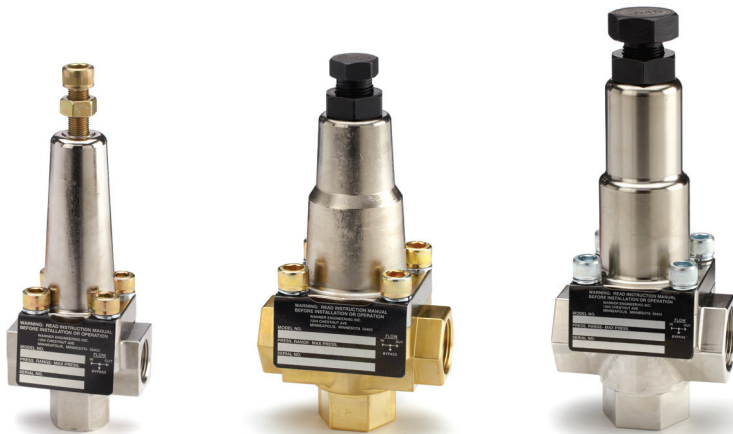

Seal-less C60 Series Valves



C Series Pressure Regulating Valves

Versatile Application for Positive Displacement Pumps

Designed for use with any positive displacement pump, Wanner C Series pressure regulating valves bypass system fluid to prevent excess system pressure. They can also be used as pressure relief valves.

When a system discharge is completely closed (e.g. closed spray gun, closed valve, plugged nozzle) these valves bypass the total system fluid flow in Wanner Hydra-Cell®, Wanner Hydra-Cell® Pro, or other positive displacement pumps. The valves also balance system pressure for multiple-gun operations.

Design Advantages



Tapered design of the C20 Series valves plunger.

The valve design is based on using a simple tapered plunger with a valve seat. When excess pressure overcomes the adjustable spring pressure on the plunger, the plunger lifts off the seat, allowing fluid to bypass and reduce system pressure.

When the valve is mounted in the discharge line, its modified flow-through design reduces wear on the plunger and seat. Baffles on either side of the plunger and seat extend valve life by directing flow around these critical components.

Seal-less Diaphragm



C60 Series valves feature a seal-less diaphragm with a tapered plunger, making the valves ideal for high-pressure requirements and handling dirty fluids.

Performance Advantages

- Accurate and repeatable.
- Adjustable.
- Immediate response.
- Smooth, chatter-free bypass.
- No external springs or moving parts.
- Flow-through design with minimal pressure surge.
- Heavy-duty construction.

Easy to Service

Wanner C Series valves can be serviced in place without removing any fittings or plumbing. Simply remove the top of the body and replace any worn internal components.



The model C62 seal-less valve is the most frequently specified pressure regulating valve in a Wanner Hydra-Cell pumping system.

Identifying Metallic Components

Since it is often difficult to distinguish between metallic materials used, identification marks have been added to several machined metallic components of Wanner pumps and valves.

Plunger (C22/C23/C24 Valves)

Identified by ridges (or no ridges) around the tapered end.

17-4 SST	2 ridges
316L SST	1 ridge
Hastelloy C	No ridges

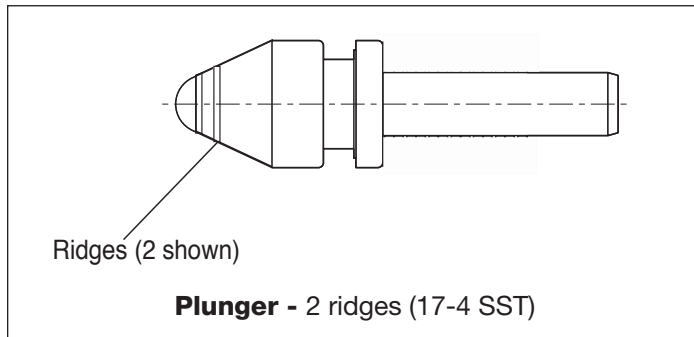

Plunger Seat (C22/C23/C24 Valves)

Identified by circular V-shaped grooves (or no grooves) on one face.

17-4 SST	2 grooves
316L SST	1 groove
Hastelloy C	No groove

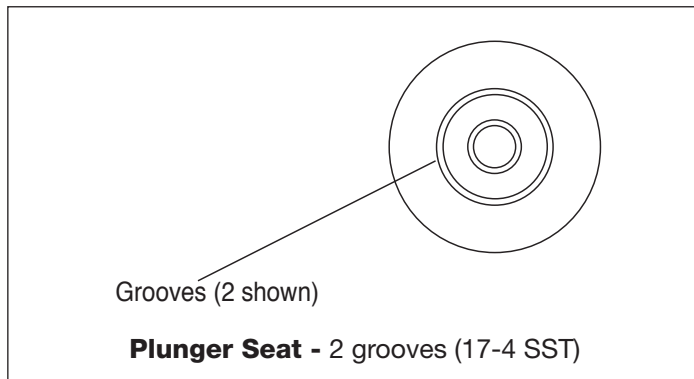

Installation Guidelines

Wanner C Series pressure regulating valves are installed on the discharge side of the pump to regulate the pressure of downstream process or equipment.

Pressure Regulator (Relief Valve) Guidelines

1. Size the pressure regulator valve so that when fully open, it will be large enough to relieve the full capacity of the pump without excessive over-pressurizing of the system.
2. Locate the valve as close to the pump as possible and ahead of any other valves.
3. Adjust the pressure regulating valve to no more than 10% over the maximum working pressure of the system. Do not exceed the manufacturer's pressure rating for the pump and/or regulator.

C20 Series Valves | Dimensions



C22 valve with Brass body

C22 with 3/4" NPT Ports Inches (mm)

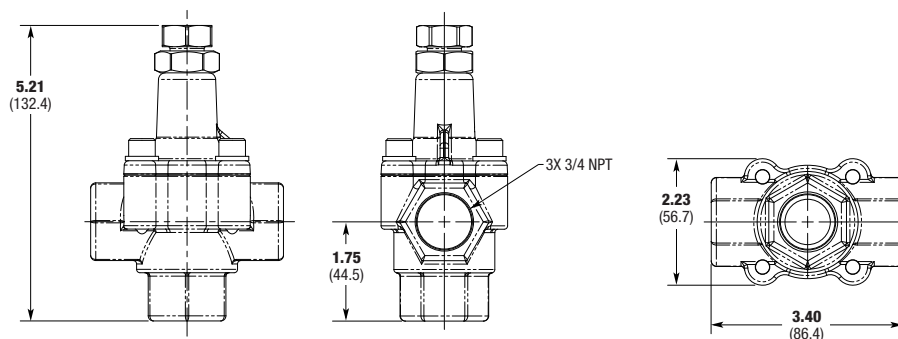

C23 valve with Stainless Steel body

C23 with 1" NPT Ports Inches (mm)

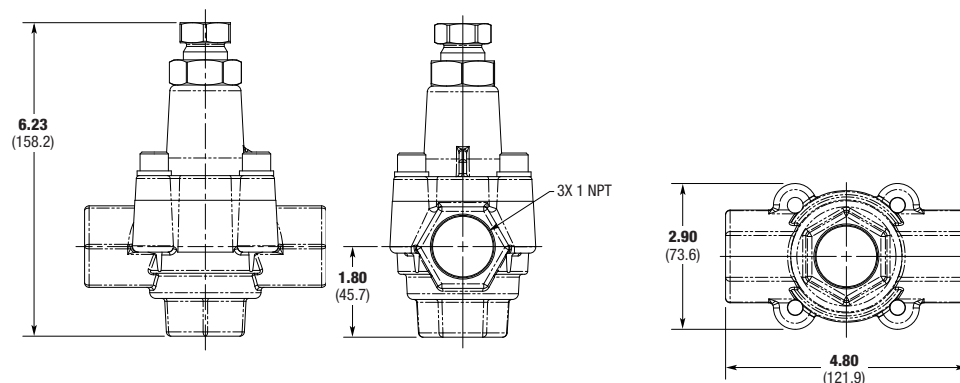

C24 valve with Brass body

C24 with 1-1/4" NPT Ports Inches (mm)

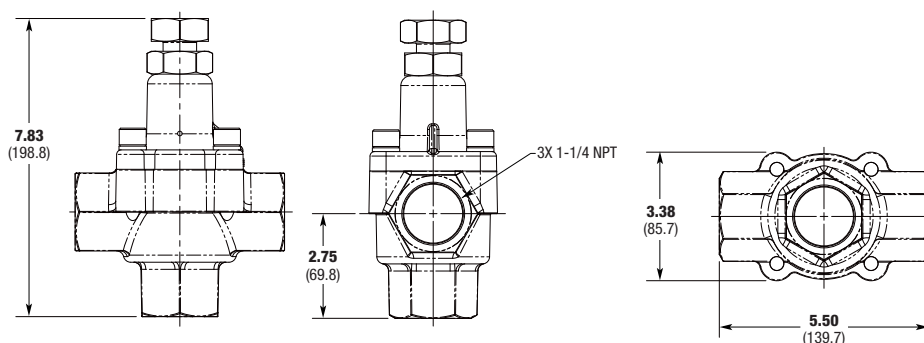

C20 Series Valves | How to Order

Ordering Information

1	2	3	4	5	6	7	8	9	10	11
C	2									

A complete C22, C23 or C24 Model Number contains 11 digits, including 8 customer-specified design and material options, for example: C22AABNSSEF.

Digit	Order Code	Description
1-3		Valve Configuration & Capacities
	C22	3-10 gpm (11.3-37.8 l/min)
	C23	3-20 gpm (11.3-75.7 l/min)
	C24	5-40 gpm (18.9-151.4 l/min)
4		Inlet/Outlet Ports
	A	NPT Ports
	D	BSPT Ports
5		Pressure Range (Spring Selection)
	A	75-500 psi (5-34 bar)
	B	500-1000 psi (34-69 bar)
	C	1000-1500 psi (69-103 bar)
6		Body/Top Material
	B	Brass/Plated Steel
	H	Hastelloy CW12MW/Plated Steel
	S	316L Stainless Steel/Plated Steel
7		Seals/Back-up Seals
	A	Urethane/UHMW Polyethylene
	B	FKM/UHMW Polyethylene
	E	EPDM/PTFE
	N	Buna-N/Buna-N
	V	FKM/PTFE
8		Valve Seats
	H	Hastelloy C
	R	316L Stainless Steel
	S	17-4 Stainless Steel
	T	Tungsten Carbide
9		Plungers
	H	Hastelloy C
	R	316L Stainless Steel
	S	17-4 Stainless Steel
	T	Tungsten Carbide
10		Seat Size
	E	For C22 Models
	J	For C23 Models
	N	For C24 Models
11		Port Size
	F	For C22 Models (3/4")
	G	For C23 Models (1")
	H	For C24 Models (1-1/4")

Specifications

Max. Temperature 200°F (93°C)

Inlet & Outlet Ports

C22	3/4" NPT
C23	1" NPT
C24	1-1/4" NPT

Weight

C22	3 lbs. (1.3 kg)
C23	6 lbs. (2.7 kg)
C24	10 lbs. (4.5 kg)

C22 valves are used with Wanner Hydra-Cell models D10 and D12.

C23 valves are used with Wanner Hydra-Cell model H25.

C24 valves are used with Wanner Hydra-Cell models D35 and D66.

C20 Series valves can be used as a lower-cost alternative to C60 Series seal-less valves when higher discharge pressures are not required.

For Installation Guidelines, and reference on identifying metallic components of C20 Series plungers and plunger valve seats, see page 3.

C46 Series Valves | Dimensions



C46 In-line with Brass body.



C46 Off-line with Stainless Steel body.



C46 Off-line with Brass body.

C46 for In-Line Mount with 3/8" NPT Ports Inches (mm)

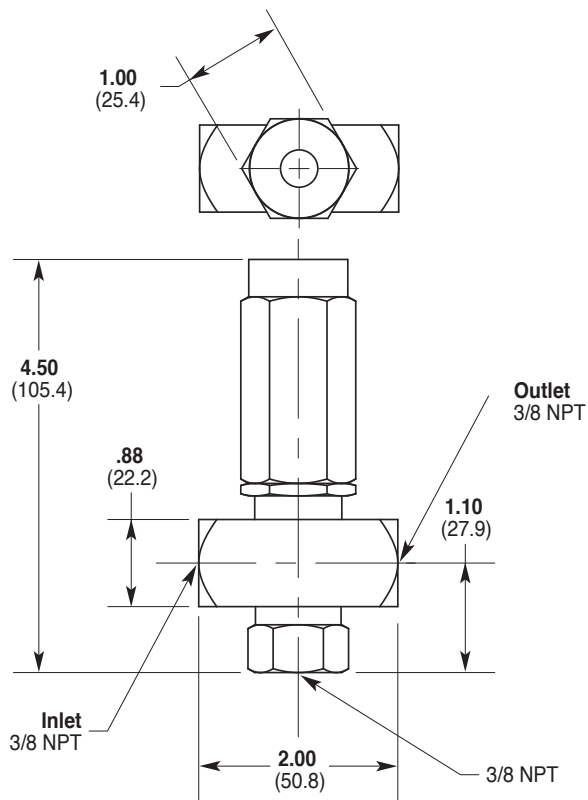

C46 for Off-Line Mount with 3/8" NPT Ports Inches (mm)

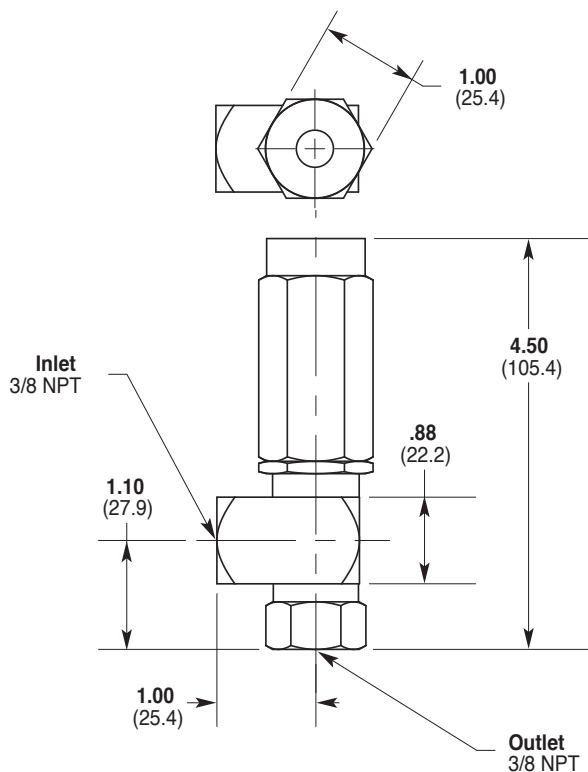

C46 Series Valves | How to Order

Ordering Information

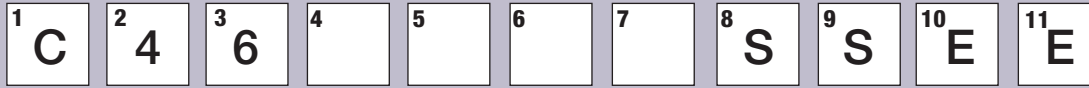

A complete C46 Model Number contains 11 digits, including 4 customer-specified design and material options, for example: C46AABESSEE

Digit	Order Code	Description
1-3	C46	Valve Configuration & Capacities Up to 7 gpm (26.5 l/min) NPT Ports
4	A B	Mounting Design In-line (Brass Only) Off-line (Brass or Stainless Steel)
5	A B C	Pressure Range (Spring Selection) Low Spring: 50-500 psi (3-34 bar) Medium Spring: 100-900 psi (7-62 bar) Standard Spring: 200-1500 psi (13-103 bar)
6	B S	Body Material Brass 316L Stainless Steel (Off-line model only)
7	E N V	O-rings EPDM Buna-N FKM
8	S	Piston 316L Stainless Steel
9	S	Seat 316L Stainless Steel
10	E	Seat Size For C46 Models
11	E	Port Size For C46 Models (3/8" NPT)

Specifications

Max. Temperature 200°F (93°C)

Max. Temperature 200°F (93°C)

Inlet & Outlet Ports 3/8" NPT

Weight 12 oz. (0.33 kg)

C46 Series valves are used with Wanner Hydra-Cell models F20, F21, F22, M03, D03, and M03 Mono-Block.

For Installation Guidelines, see page 3.

C60 Series Valves | Dimensions



C62 valve with Stainless Steel body

C62 with 3/4" NPT Ports Inches (mm)

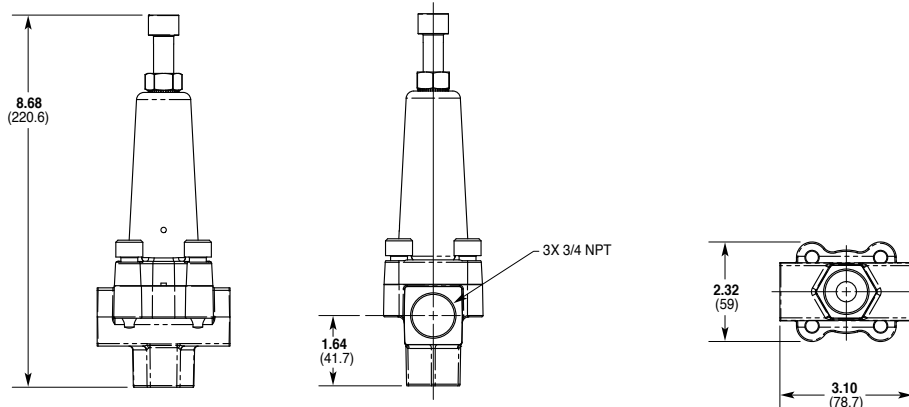

C63 valve with Brass body

C63 with 1" NPT Ports Inches (mm)

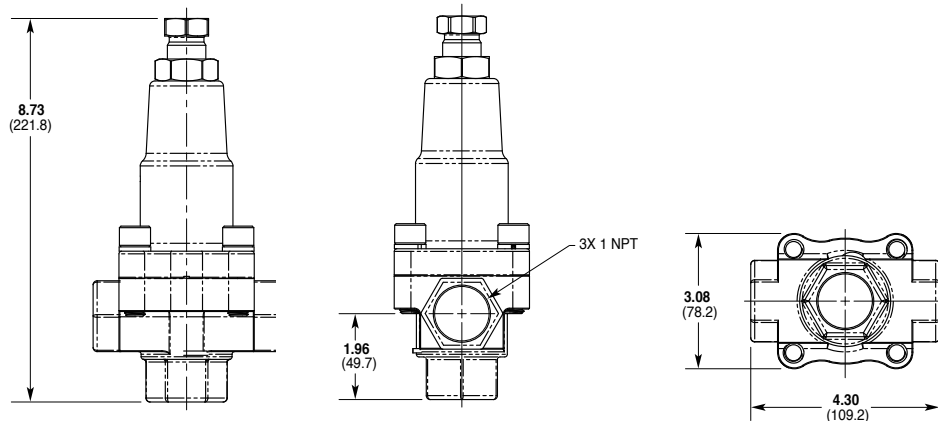

C64 valve with Stainless Steel body

C64 with 1-1/4" NPT Ports Inches (mm)

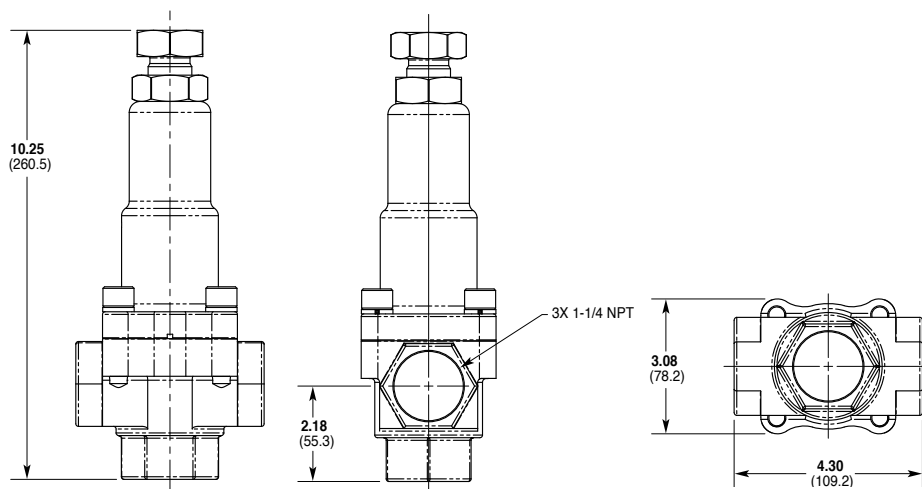

C60 Series Valves | How to Order

Ordering Information

1	2	3	4	5	6	7	8	9	10	11
C	6									

A complete C62, C63 or C64 Model Number contains 11 digits, including 8 customer-specified design and material options, for example: C62ABBSSEF.

Digit	Order Code	Description
1-3		Valve Configuration & Capacities
	C62	1-14 gpm (3-53.0 l/min)
	C63	1-25 gpm (3-94.6 l/min)
	C64	1-40 gpm (3-151.4 l/min)
4		Inlet/Outlet Ports
	A	NPT Ports
	D	BSPT Ports
5		Pressure Range (Spring Selection)
	A	C62: 75-500 psi (5-34 bar) C63: 75-1000 psi (5-69 bar) C64: 75-1000 psi (5-69 bar)
	B	C62: 500-2500 psi (34-172 bar) C63: 1000-2500 psi (69-172 bar) C64: 1000-2500 psi (69-172 bar)
6		Body/Top Material
	B	Brass/Plated Steel
	H	Hastelloy C/Plated Steel (available for C62 only)
	S	316L Stainless Steel/Plated Steel
7		O-rings/Diaphragm
	J	PTFE/PTFE
	V	FKM/PTFE
8		Valve Seats
	H	Hastelloy C (available for C62 only)
	R	316L Stainless Steel
	S	17-4 Stainless Steel
	T	Tungsten Carbide (available for C62 only)
9		Plungers
	H	Hastelloy C (available for C62 only)
	R	316L Stainless Steel
	S	17-4 Stainless Steel
	T	Tungsten Carbide (available for C62 only)
10		Seat Size
	E	For C62 Models
	J	For C63 Models
	N	For C64 Models
11		Port Size
	F	For C62 Models (3/4")
	G	For C63 Models (1")
	H	For C64 Models (1-1/4")

Hastelloy C Body available only for C62 models.

Hastelloy C and Tungsten Carbide Valve Seat/Plunger options available only for C62 models.

C62 models fitted with Tungsten Carbide Valve Seats/Plungers rated to 1800 psi (124 bar) maximum.

For Installation Guidelines, see page 3.

Specifications

Max. Temperature 200°F (93°C)

Inlet & Outlet Ports

C62	3/4" NPT
C63	1" NPT
C64	1-1/4" NPT

Weight

C62	4.0 lbs. (1.8 kg)
C63	6.2 lbs. (2.8 kg)
C64	7.2 lbs. (3.3 kg)

C62 valves are recommended for Wanner Hydra-Cell models D04, D10, D12, and D15/D17.

C63 valves are recommended for Wanner Hydra-Cell model H25.

C64 valves are recommended for Wanner Hydra-Cell models D35 and D66.

The model C62 seal-less valve is the most frequently specified pressure regulating valve in a Wanner Hydra-Cell pumping system.

Partners in over 70 countries

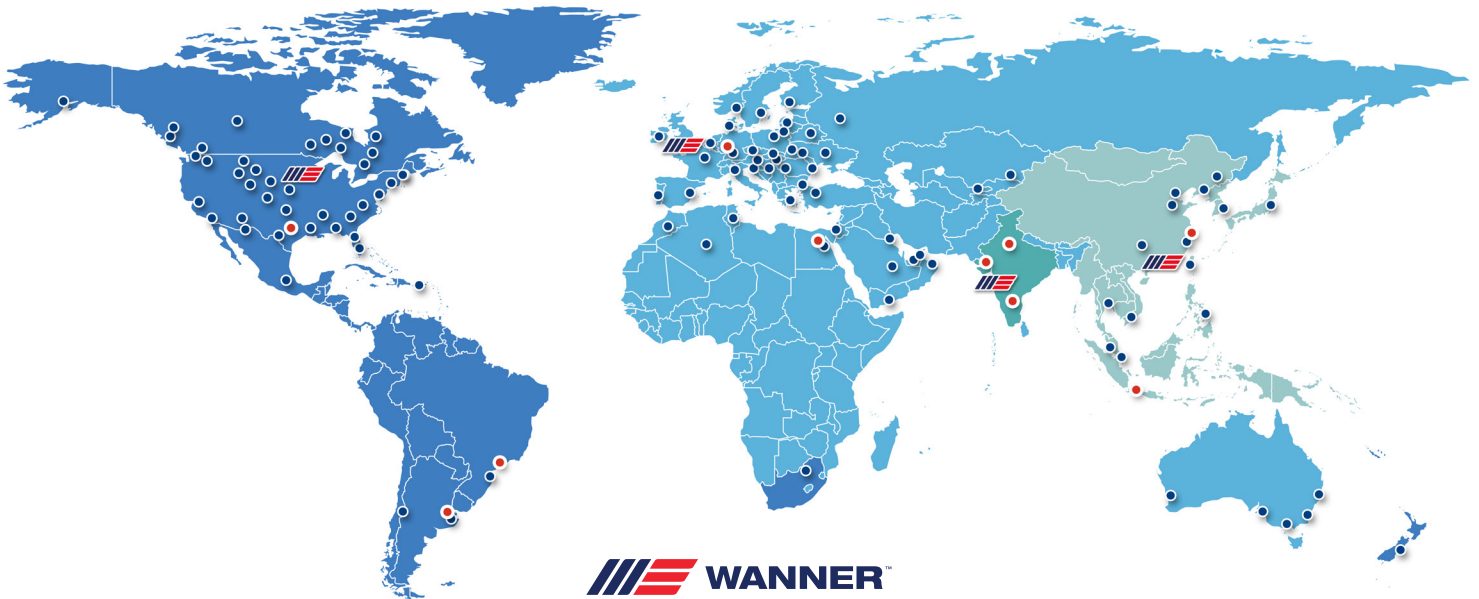



WANNER™
Global Sales and Technical Support



Americas

-  Minneapolis, Minnesota USA
-  Wichita Falls, Texas USA
-  São Paulo, Brazil
-  Buenos Aires, Argentina





EMEA | Australia

-  Hampshire, United Kingdom
-  Cairo, Egypt
-  Remagen, Germany

Asia | Pacific

-  Kowloon, Hong Kong
-  Shanghai, China
-  Jakarta, Indonesia

India

-  Mumbai, India
-  New Delhi
-  Bangalore
-  Gujarat

Wanner worldwide

GLOBAL SALES & TECHNICAL SUPPORT

WANNER ENGINEERING, INC.

WORLD HEADQUARTERS & MANUFACTURING

Minneapolis, Minnesota USA
t: 612-332-5681
e: sales@wannereng.com
Hydra-Cell.com

REGIONAL OFFICE

Wichita Falls, Texas USA
t: 940-322-7111
e: sales@wannereng.com

LATIN AMERICAN OFFICE

São Paulo, Brazil
t: +55 (11) 99582-1969
e: mmagoni@wannereng.com
Hydra-Cell-Pumps.com.br

WANNER INTERNATIONAL, LTD.

UNITED KINGDOM

8 & 9 Fleet Business Park
Sandy Lane • Church Crookham
Hampshire UK GU52 8BF

t: +44 (0) 1252 816847
e: support@wannerint.com
Hydra-Cell.co.uk

WANNER PUMPS, LTD.

Kowloon, HONG KONG

t: +852 3428 6534
e: sales@wannerpumps.com
WannerPumps.com

Shanghai, CHINA

t: +86-21-6876 3700
e: sales@wannerpumps.com
WannerPumps.com

WANNER INDIA PVT. LTD.

Mumbai, INDIA

t: +91 (22) 22044766
e: support@wannerindia.com
WannerIndia.com

