

INSTALLATION & SERVICE

D17-991-2400A

Hydra-Cell[®]

INDUSTRIAL PUMPS

Models: D-17, G-17

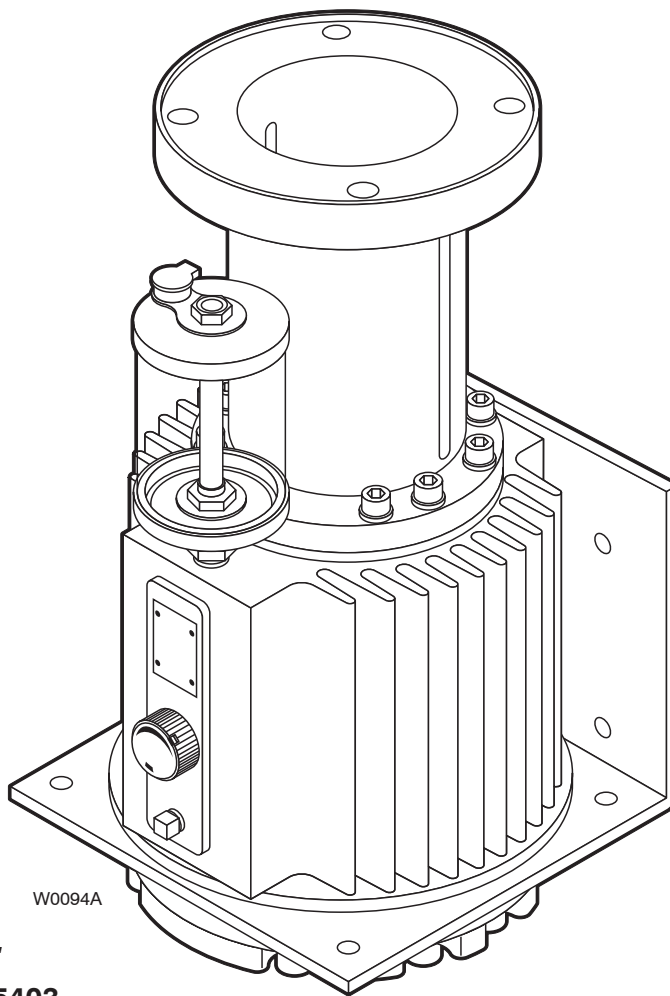

W0094A



WANNER ENGINEERING, INC.

1204 Chestnut Avenue, Minneapolis, MN 55403

TEL: (612) 332-5681 FAX: (612) 332-6937

TOLL-FREE FAX [US only]: (800) 332-6812

www.hydra-cell.com

email: sales@wannereng.com

D/G-17 Contents

	Page
Specifications.....	2
Dimensions	4
Installation.....	6
Maintenance.....	10
Service (Fluid End)	11
Service (Hydraulic End)	15
Troubleshooting.....	18
Warranty.....	20

D/G-17 Specifications

Max Pressure

1500 psi (100 bar) @ 1750 rpm
(D/G-17-E Cam only);
2000 psi (138 bar) @ 1450 rpm;
2500 psi (172 bar) @ 1150 rpm

Capacity @ Rated Pressure

	rpm	psi	bar	gpm	l/min
D/G-17-X	1450	500	35	13.4	50
	1450	1500	100	13.0	48
	1450	2000	140	12.7	48
D/G-17-E	1150	2500	170	10.3	39
	1750	500	35	15.1	57
	1750	1500	100	14.1	53
	1450	2000	140	11.5	44
	1150	2500	170	9.4	35

Delivery @ Rated Pressure

	psi	bar	revs/gal	
revs/liter				
D/G-17-X	500	35	109	28.8
	1500	100	112	29.6
	2000	140	114	30.2
	2500	170	112	29.6
D/G-17-E	500	35	116	30.6
	1500	100	124	32.8
	2000	140	126	33.3
	2500	170	122	32.3

Max Inlet Pressure 500 psi (35 bar)

Max Temperature 250°F (121°C) – consult factory for temperatures above 180°F (82°C)

Inlet Port*
D-17: 1-1/4 inch NPT
G-17: 1-1/4 inch BSPT

Discharge Port*
D-17: 3/4 inch NPT
G-17: 3/4 inch BSPT

Shaft Diameter 1-1/8 inch (28.58 mm)

Shaft Rotation Bi-directional

Bearings Tapered roller bearings

Oil Capacity 2.9 US quarts (2.8 liters)

Weight 145 lbs (66 kg)

Calculating Required Horsepower (kW)*

$$\frac{80 \times \text{rpm}}{63,000} + \frac{\text{gpm} \times \text{psi}}{1,460 - \left(\frac{\text{psi} - 500}{20}\right)} = \text{electric motor HP}^*$$

$$\frac{80 \times \text{rpm}}{84,428} + \frac{\text{gpm} \times \text{bar}}{511 - \left(\frac{\text{bar} - 35}{4}\right)} = \text{electric motor kW}^*$$

* rpm equals pump shaft rpm. HP/kW is required application power. Use caution when sizing motors with variable speed drives.

D/G-17 Specifications

Performance

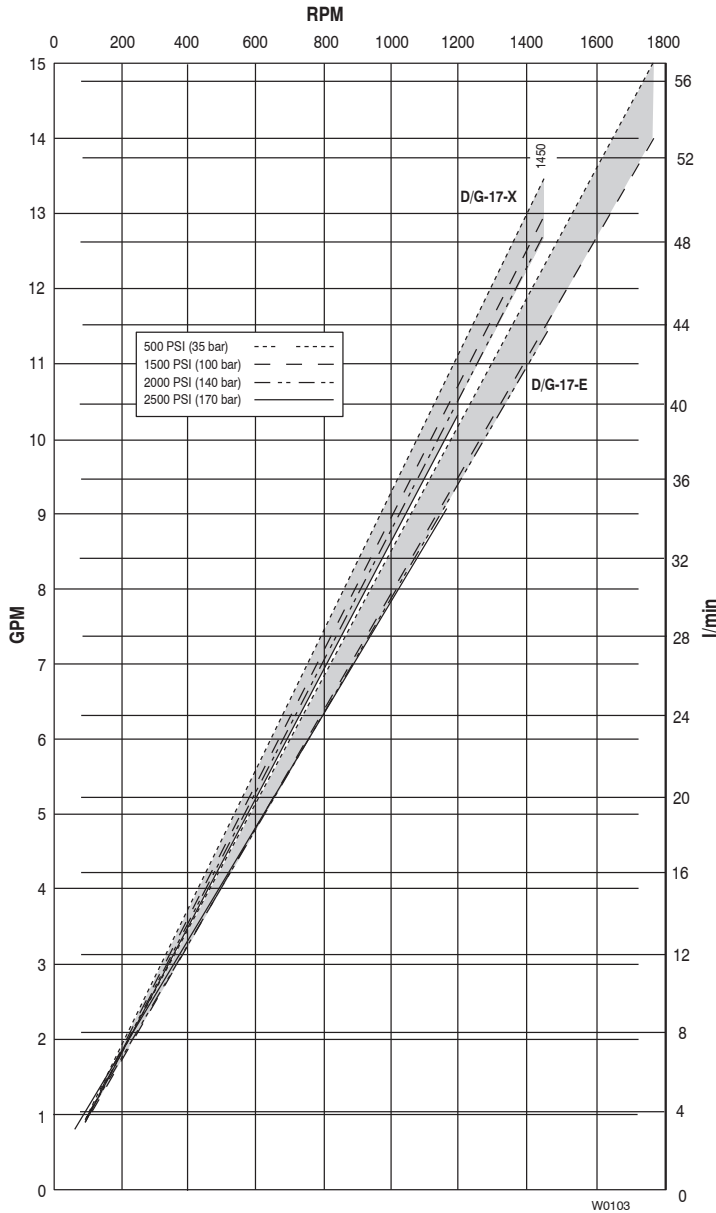

*Pump NPSHr and Lift performance based on randomly selected pumps with water at 70°F (21°C)

Net Positive Suction Head - NPSHr

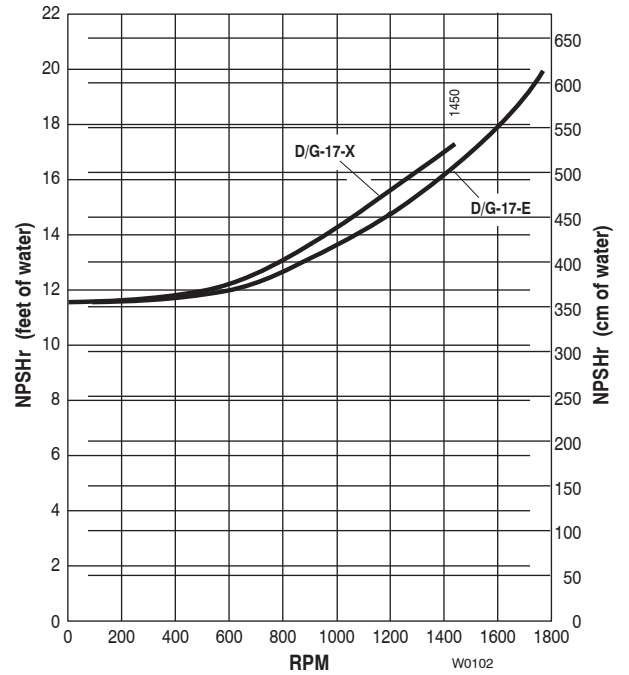

Dry Lift

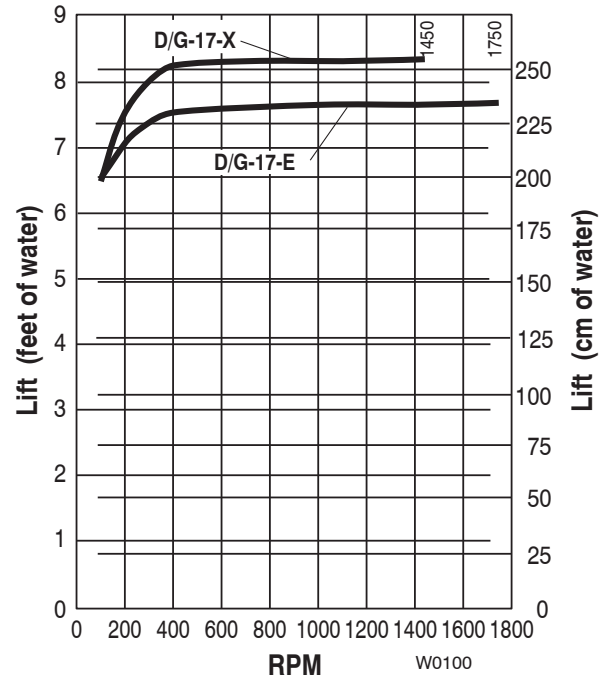

D/G-17 Specifications

Dimensions

inches (mm)

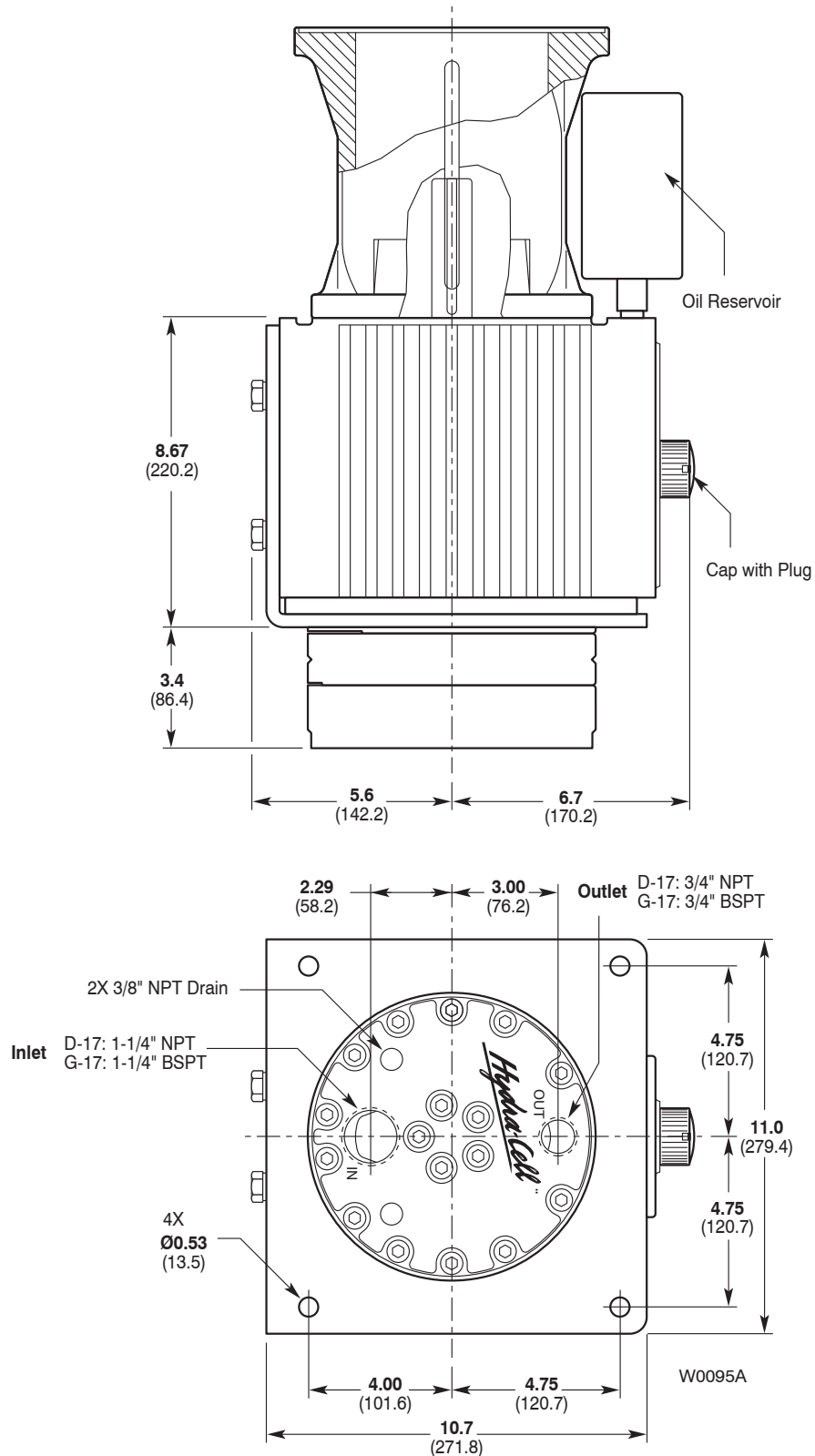

D/G-17 Specifications

Dimensions

inches (mm)

NEMA Adapters: A04-041-1200; A04-041-1202
IEC Adapter: A04-041-1203

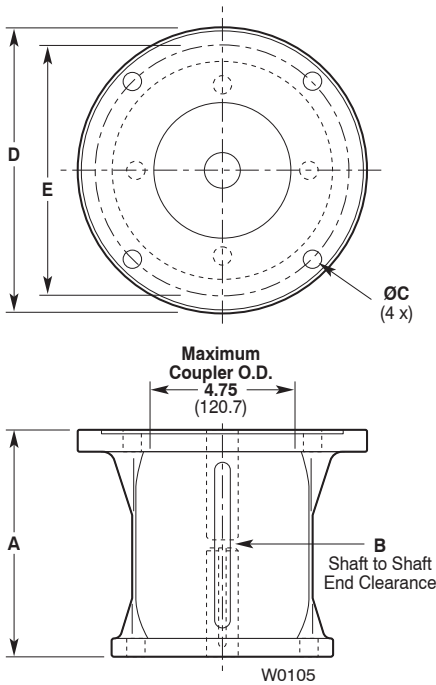

IEC Adapters: A04-041-1201; A04-041-1205

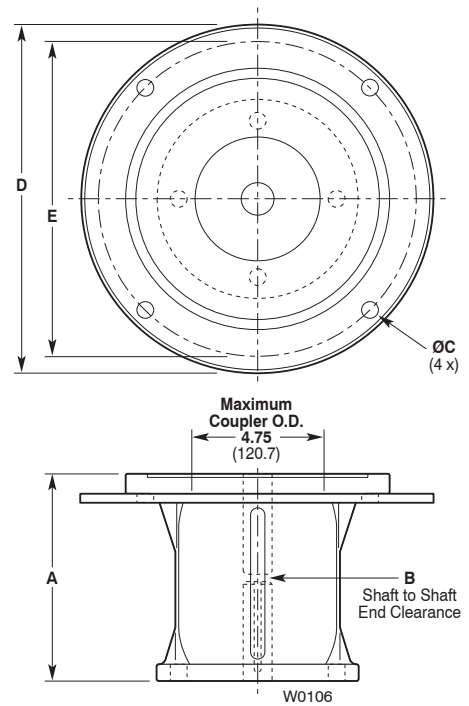

Kit Part Number	Adapter Kit Motor Size	Dimensions in (mm)					
		A	B	C	D	E	F
A04-041-1200	NEMA 182/184TC	8.75	7.25	0.54	8.0	1.71	1.125
	NEMA 213/215TC	8.75	7.25	0.54	8.0	0.96	1.375
	NEMA 254/256TC	8.75	7.25	0.54	8.0	0.33	1.625
A04-041-1202	NEMA 284/286TC	10.75	9.00	0.54	8.4	0.14	1.875
A04-041-1203	IEC 160 B14 Face	(250)	(215)	(13.1)	(208.3)	(3.8)	(42)
A04-041-1201	IEC 132 B5 Flange	(328)	(265)	(13.1)	(203.2)	(27.7)	(38)
A04-041-1205	IEC 160/180 B5 Flange	(328)	(300)	(17.0)	(208.3)	(3.8)	(42/48)

D/G-17 Installation

Important Precautions

Adequate Fluid Supply. To avoid cavitation and premature pump failure, be sure that the pump will have an adequate fluid supply and that the inlet line will not be obstructed. See “Inlet Piping”.

Positive Displacement. This is a positive-displacement pump. To avoid severe system damage if the discharge line ever becomes blocked, install a relief valve downstream from the pump. See “Discharge Piping”.

Safety Guards. Install adequate safety guards over all pulleys, belts, and couplings. Follow all codes and regulations regarding installation and operation of the pumping system.

Shut-Off Valves. Never install shut-off valves between the pump and discharge pressure regulator, or in the regulator bypass line.

Freezing Conditions. Protect the pump from freezing. See also the Maintenance Section.

Consult the Factory for the following situations:

- Extreme temperature applications (above 160° F or below 40° F)
- Pressure feeding of pumps
- Viscous or abrasive fluid applications
- Chemical compatibility problems
- Hot ambient temperatures (above 110° F)
- Conditions where pump oil may exceed 200° F because of a combination of hot ambient temperatures, hot fluid temperature, and full horsepower load — an oil cooler may be required

Location

NOTE: The numbers in parentheses are the Reference Numbers on the exploded view illustrations found later in this manual and in the Parts Manual.

The D-17 and G-17 pumps are designed to run vertically with the head submerged in the fluid being pumped. The pump/motor must be rigidly mounted to the fluid supply tank. Note: the fluid supply tank must be capable of supporting the weight of the pump/motor assembly (see next sections of Installation instructions for more details). Allow enough space for the assembly to be raised and lowered from the supply tank for servicing. Note: hydraulic end oil can be changed (drained and refilled) without removing the pump from its installation on the fluid supply tank.

Construction of the Tank

The Installation Illustration shows the recommended minimum inside height, the top cutout, and the hole size and locations required to mount the pump base. Determine the desired pump orientation before drilling the mounting holes, as the hole pattern in the pump base plate is not symmetric.

Construct the tank so it will adequately support the weight of the pump/motor assembly. The combined pump/motor weight could be up to 650 lbs (295 kg). Consult the motor manufacturer for the actual motor weight.

Typical machine tool coolant tanks are of sheet metal construction and will not adequately support the D-17 or G-17 pump/motor assembly. Risers inside the tank, support plates, weld nuts, and other techniques should be used to ensure the pump/motor assembly will be secure. Additionally, the pump and mounting must be able to withstand vibrations and on/off shocks that will be present as the pump runs and cycles on and off with demand.

The tank should be large enough to avoid aerating the fluid. Return flow from the system as well as bypass from the pressure regulating valve should be returned to the tank as far away from the pump inlet as practical. Preferably in an isolated section of the tank, baffled from area the pump sits in.

Mounting the Pump

Isolate the pump and tank from the system by using flexible high pressure hose from the discharge piping and flexible wiring to the motor. Allow long enough flexible hose and wiring for removal of the complete pump/motor assembly from the supply tank, or attach quick disconnect fittings for easy maintenance.

With the discharge fluid connection secure and the unit in place on the supply tank, fasten the pump base plate to the tank using four 1/2” or 12mm cap screws. Use lock washers beneath the heads of the cap screws and torque to 30 ft-lbs (40 N-m).

D/G-17 Installation

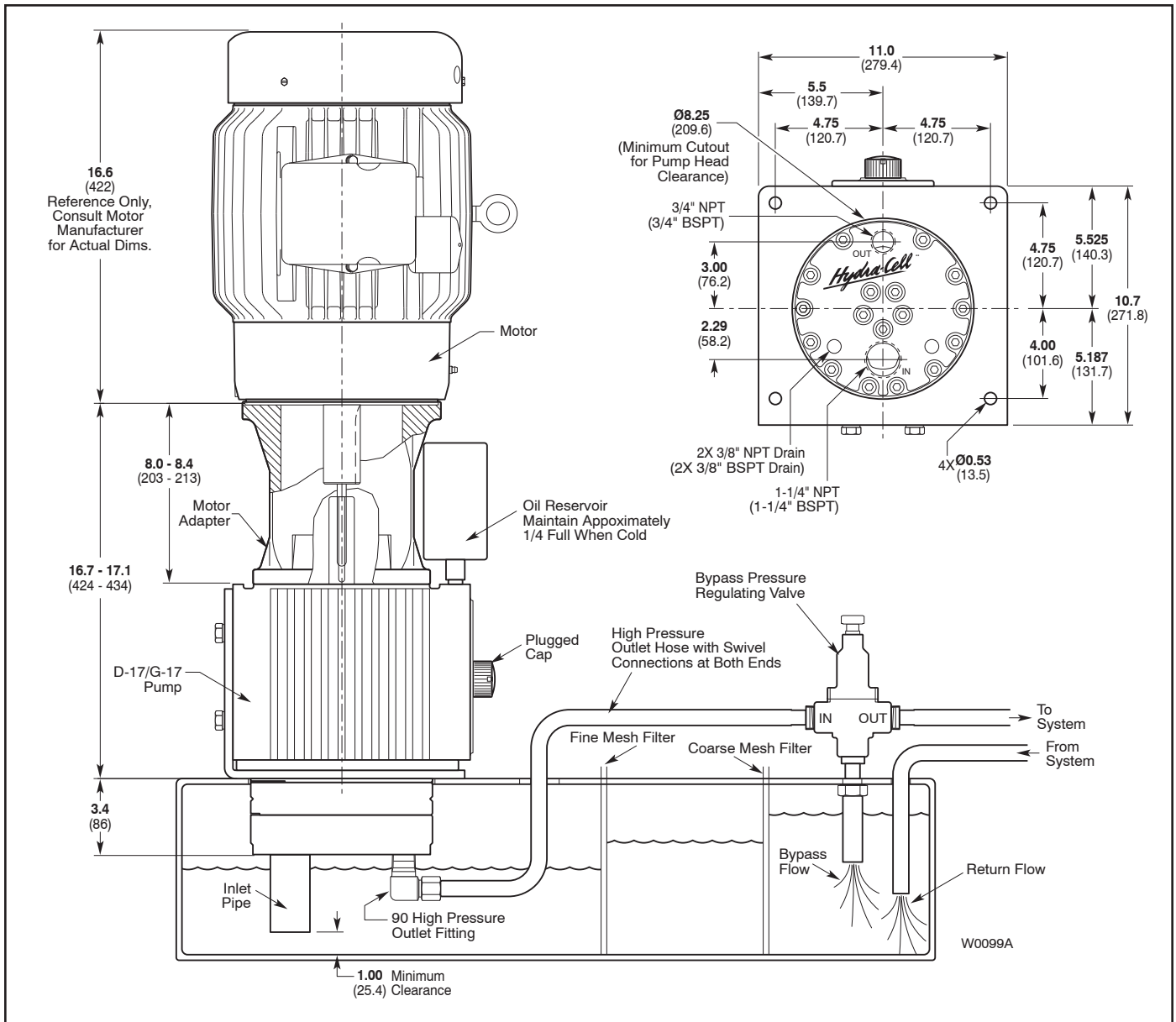

Inlet Piping

Before entering the section of the tank where the pump inlet is submersed, the fluid should be filtered to one size smaller than the smallest nozzle or tool orifice in the system. Set up baffling in the tank to allow chips and large particles to settle out before getting close to the pump inlet. Install at least two stages of filtering to ensure an adequate supply of fluid to the pump inlet: a coarse mesh followed by a fine mesh to section off the tank closest to the pump. Install the filters in the tank where they can be checked and cleaned regularly; plugged filters can result in pump cavitation, drop in volume or pressure output, or damage to the pump. Do not connect a line strainer or filter directly onto the pump inlet port.

If the fluid being pumped gets too hot a chiller may be required. If pumping machine tool coolant, operate below the manufacturers maximum temperature rating for the coolant.

If using the pump isolated from the supply tank, with the inlet fed by a hose or pipe, consult the factory for instructions regarding "Inlet Piping (Suction Feed)", "Inlet Piping (Pressure Feed)", and "Inlet Calculations (Acceleration Head, Friction Losses, and NPSH)". Specific instructions for this situation can also be found in the D15-991-2400 Installation/Service Manual.

DG-17 Installation

Discharge Piping

NOTE: Consult the Factory before manifolding two or more pumps together.

Hose and Routing

Use the shortest, most-direct route for the discharge line.

Select pipe or hose with a **working pressure** rating of at least 1.5 times the maximum system pressure. EXAMPLE: Select a 3000-psi W.P.-rated hose for systems to be operated at 2000-psi-gauge pressure.

Use about 6 ft (1.8 m) of flexible hose between the pump and rigid piping to absorb vibration, expansion or contraction, and to isolate the pump/motor/tank from the system.

Size the discharge line so that the velocity of the fluid will not exceed 7-10 ft/sec (2-3 m/sec):

For pipe in inches: Velocity (ft/sec) = $0.408 \times \text{GPM}/\text{Pipe ID}^2$

For pipe in mm: Velocity (m/sec) = $21.2 \times \text{LPM}/\text{Pipe ID}^2$

Pressure Regulation

Install a pressure regulator or unloader in the discharge line. Bypass pressure must not exceed the pressure limit of the pump.

Size the regulator so that, when fully open, it will be large enough to relieve the full capacity of the pump without overpressurizing the system.

Locate the valve as close to the pump as possible and ahead of any other valves.

Adjust the pressure regulating valve to no more than 10% over the maximum working pressure of the system. Do not exceed the manufacturer's pressure rating for the pump or regulator.

Mount the bypass pressure regulator to the supply tank as far away from the pump inlet as practical, preferably in an isolated section of the tank, baffled from the pump.

If the pump may be run for a long time with the discharge closed and fluid bypassing, install a thermal protector in the bypass line (to prevent severe temperature buildup in the bypassed fluid).

CAUTION: Never install shutoff valves in the bypass line or between the pump and pressure regulator or relief valve.

Provide for permanent or temporary installation of a pressure gauge to monitor the discharge pressure at the pump.

For additional system protection, install a safety relief valve in the discharge line, downstream from the pressure regulator.

D/G-17 Installation

Before Initial Start-Up

Before you start the pump, be sure that:

- The pipe plug in the pump housing has been removed and the oil reservoir (39) has been installed. The reservoir allows for oil expansion during pump operation, and serves as a sight glass for monitoring condition and level of the oil. Fill the oil reservoir 1/4 full when the pump is cold.
- All shutoff valves are open, and the pump has an adequate supply of fluid.
- All connections are tight.
- The relief valve on the pump outlet is adjusted so the pump starts under minimum pressure. This allows air in the system to be expelled easily, and fluid to enter the pump and system.
- The coupler that connects the pump and motor shafts has been sized and installed correctly.
- All electrical wiring has been done correctly to electrical codes.

Initial Start-Up Procedure

1. Turn on power to the pump motor.
2. Listen for any erratic noise, and look for unsteady flow. If the pump does not clear, refer to the Trouble-shooting Section.
3. If the system has an air lock and the pump fails to prime:
 - a. Turn off the power.
 - b. Disconnect the discharge hose from the inlet port of the pressure regulating valve (refer to installation illustration.)

NOTE: Fluid may come out when the hose is removed. Provide an adequate catch basin for fluid spillage, if required. Fluid will come out of this hose when the pump is started; route the hose back to the supply tank or to a catch basin so fluid will not be sprayed or lost. Use high-pressure-rated hose and fittings. Take all safety precautions to assure safe handling of the fluid being pumped.

- c. Jog the system on and off until the fluid coming from this port is air-free.
 - d. Turn off the power.
 - e. Reconnect the discharge hose to the inlet port of the pressure regulating valve.
4. Adjust the discharge pressure regulator to the desired operating and bypass pressures. Do not exceed the maximum pressure rating of the pump.
 5. After the pressure regulator is adjusted, set the safety relief valve at 100 psi (7 bar) higher than the desired operating pressure. To verify this setting, adjust the discharge pressure regulator upward until the relief valve opens. Follow the recommendations in the above NOTE (step 3b) for handling the fluid that will come from the relief valve.
 6. Reset the discharge pressure regulator to the desired system pressure.
 7. Provide a return line from the relief valve to the supply tank.

D/G-17 Maintenance

Daily

NOTE: The numbers in parentheses are the Reference Numbers on the exploded view illustrations found later in this manual and in the Parts Manual.

Check the oil level and the condition of the oil. The oil reservoir should be 1/4 full.

Use the appropriate Hydra-Oil for the application (contact Wannier Engineering if in doubt).

CAUTION: If you are losing oil but don't see any external leakage, or if the oil becomes discolored and contaminated, one of the diaphragms (21) may be damaged. Refer to the Fluid-End Service Section. Do not operate the pump with a damaged diaphragm.

CAUTION: Do not leave contaminated oil in the pump housing or leave the housing empty. Remove contaminated oil as soon as discovered, and replace it with clean oil.

Periodically

Change the oil after the first 100 hours of operation, then change according to the guidelines below. When changing, remove the drain plug cap (26) at the bottom of the pump so all oil and accumulated sediment will drain out. Then, remove the magnetic plug (33) and clean all accumulated debris from it. Replace the magnetic plug and drain plug cap and refill with the appropriate Hydra-Oil.

Hours Between Oil Changes @ Various Process Fluid Temperatures

Pressure	RPM	<90°F (32°C)	<139°F (60°C)	<180°F (82°C)
<1500 psi (100 bar)	<1200	4,000	3,000	2,000
	<1750	2,000	1,500	1,000
<2000 psi (140 bar)	<1200	2,000	—	1,500
	<1450	1,500	—	1,000
<2500 psi (170 bar)	<1200	1,500	—	1,000

NOTE: Minimum oil viscosity for proper hydraulic end lubrication is 16-20 cST (80-100 SSU).

NOTE: Use of an oil cooler is recommended when process fluid and/or hydraulic end oil exceeds 180°F (82°C).

CAUTION: Do not turn the drive shaft while the oil reservoir is empty.

Check the inlet pressure or vacuum periodically with a gauge. If vacuum at the pump inlet exceeds 7 in. Hg (180 mm Hg), check the inlet piping system for blockages. If the pump inlet is located above the supply tank, check the fluid supply level and replenish if too low.

CAUTION: Protect the pump from freezing. Refer also to the "Shutdown Procedure".

Shutdown Procedure During Freezing Temperatures

Take all safety precautions to assure safe handling of the fluid being pumped. Provide adequate catch basins for fluid drainage and use appropriate plumbing from drain ports, etc. when flushing the pump and system with a compatible antifreeze.

1. Adjust the discharge pressure regulating valve so the pump runs under minimum pressure. Stop the pump.
2. Drain supply tank; open any draincocks in system piping and collect drainage; remove plugs (0) from manifold and collect drainage.
3. Close draincocks in system piping and replace manifold plugs.
4. Fill supply tank with enough antifreeze to fill system piping and pump.
Note: disconnect the system return line from the supply tank and connect it to a separate reservoir.
5. Start the pump and allow it to run until the system is filled with antifreeze. Note: if the system has an airlock and the pump fails to prime, follow step 4 of the Initial Start-up Procedure to clear the air.
6. When mostly antifreeze is flowing from the system return line stop the pump. Connect the system return line back to the supply tank and circulate the antifreeze for a short period.
7. It is also good practice to change the oil in the Hydraulic End before storage for an extended period. This will remove any accumulated condensation and sediment from the oil reservoir. Drain and refill the Hydraulic End with the appropriate Hydra-Oil and operate the pump for a short period to assure smooth performance.

D/G-17 Service (Fluid End)

DETAIL "A" (Valve Assemblies)

INLET VALVE

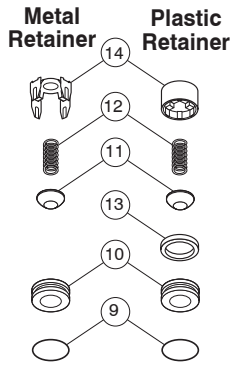

OUTLET VALVE

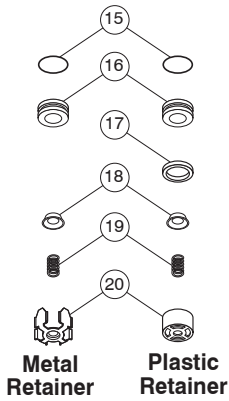

See Pump/Motor
Adapters for details

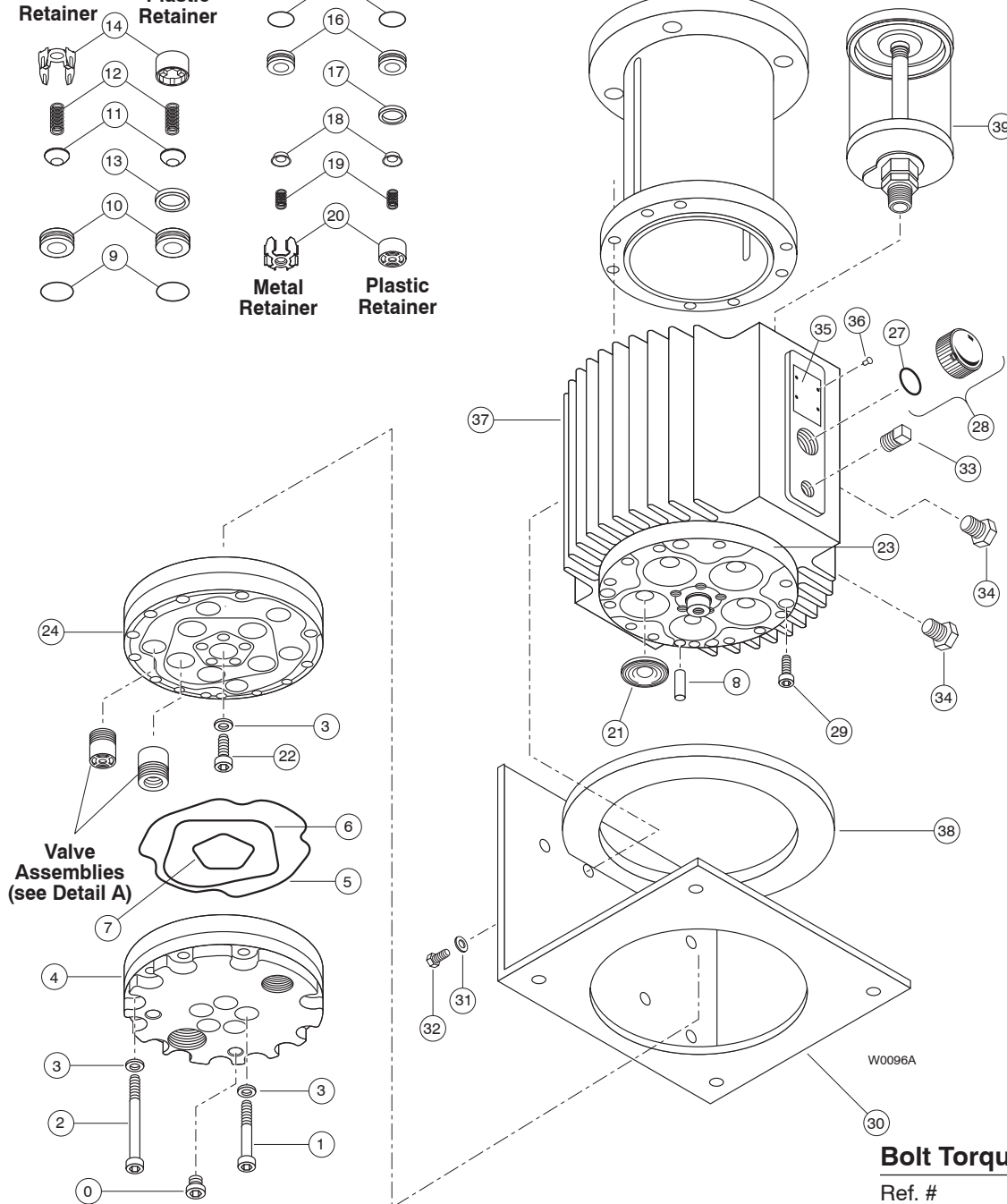

W0096A

Bolt Torque Specifications

Ref. #	Assembly Torque
1	45 ft-lbs 60 N-m
2	45 ft-lbs 60 N-m
22	45 ft-lbs 60 N-m
29	15 ft-lbs 20 N-m
32	45 ft-lbs 60 N-m
42	25 ft-lbs 35 N-m

D/G-17 Service (Fluid End)

NOTE: The number in parentheses are the Reference numbers on the illustration on the preceding page and in the Parts Manual.

This section explains how to disassemble and inspect all easily serviceable parts of the pump. Repair procedures for the hydraulic end (oil reservoir) of the pump are included in a later section of the manual.

CAUTION: Do not disassemble the hydraulic end unless you are a skilled mechanic. For assistance, contact Wanner Engineering (TEL 612-332-5681 or FAX 612-332-6937) or the distributor in your area.

CAUTION: Don not remove the four socket-head capscrews (29) that go through the cylinder housing (23), unless you are repairing the hydraulic end of the pump.

Tools and Supplies

The following tools and supplies are recommended for servicing the pump:

- Straightedge (at least 8 in. long)
- Grease or petroleum jelly
- 1/2" drive torque wrench, rated to at least 50 ft-lbs (70 N-m)
- Emery cloth and Scotch-Brite™ pad
- 11/16" socket (3/8" or 1/2" drive)
- 19 mm socket (1/2" drive)
- 3/8" drive socket wrench with extensions
- 1/2" drive socket wrench with extensions
- 5/16" (8 mm) open-end wrench
- Wanner Hydra-Oil (appropriate Grade, as determined by digit 12 of your pump model number).
- Anaerobic seal sealant (for shaft seals if servicing Hydraulic End)
- Wanner D-15 Tool Kit, which includes the following:
 - Valve seat puller
 - Plunger guide lifter
 - 3/32 x 6 in. T-handle hex wrench
 - 8 mm hex bit socket (1/2" drive)
 - Shaft rotator
 - Seal protector
 - Seal inserter
 - 5/16" hex Allen wrench
 - 7/16" 8-point socket (3/8" drive)
 - 6 mm hex Allen wrench

Service Procedures

Begin with the pump assembly removed from the system, and the pump disconnected from the motor and motor adapter. Secure the pump baseplate (30) to a stable workbench with clamps, or bolts and nuts (the bolts passing through the unused holes in the solid portion of the baseplate).

1. Remove Manifold (4) and Valve Plate (24)

- a. **Manifold.** Use the 8 mm hex bit socket included in the Wanner D-15 Tool Kit to remove the 12 capscrews (2) and five capscrews (1) at the front of the manifold. Remove and inspect the manifold for warping or wear around the inlet and outlet ports and flow channels. If wear is excessive replace the manifold. To check if the manifold is warped, place a straightedge across it; check both sides. A warped manifold should be replaced.
- b. **Valve Plate.** Using the 8 mm hex bit socket remove capscrew (22). Remove and inspect the valve plate in the same manner as the manifold, for excessive wear or warping. Replace if necessary.

CAUTION: Don't turn the pump drive shaft while the manifold and valve plate are off the pump, except when removing diaphragms or repriming the hydraulic cells.

2. Remove and Inspect Valves (9-20)

NOTE: Wanner Valve Kits include items and all O-rings for sealing the manifold to the valve plate. The five inlet and five outlet valve assemblies are different in size and face in opposite directions.

- a. Remove the inlet valve seat (10) using the seat puller tool included in the Wanner D-15 Tool Kit. Inspect the valve seat for wear, and replace if necessary.

NOTE: Whenever any valve or seat is replaced it is recommended to replace all valve assemblies to ensure the most reliable operation. All necessary parts are included in a replacement Valve Kit.
- b. Remove the remaining inlet valve components (11-14) and outlet valve components (17-20) by hand or with a small needle nose pliers.
- c. Check the spring retainers (14, 20) and replace if worn, cracked, or damaged.
- d. Check the valve springs (12, 19) and replace if worn, broken, or shorter than a new spring. Never attempt to stretch a used spring.

D/G-17 Service (Fluid End)

- e. Check the valves (11, 18) for wear or damage and replace if necessary. Polishing of the valves during operation is normal. If you can feel a ridge in the valve surface the valve should be replaced.
NOTE: Pumps with plastic spring retainers (14, 20) include a Tetra Seal (13, 17 - square section O-ring) between the spring retainer and valve seat. Pumps with metal spring retainers do not include a Tetra Seal.
- f. Reinstall the valve assemblies:
 - Clean the valve ports and shoulders in the valve plate (24) with a Scotch-Brite pad or fine emery cloth. Wash the valve plate after cleaning, and lubricate the valve ports with a compatible grease, oil, or petroleum jelly.
 - Install new O-rings (9, 15) on seats (10, 16) and lubricate all O-rings.
 - Inlet Valves (five center, larger valves). Insert the spring retainer (14) into the valve plate (24), followed by the Tetra seal (13) if spring retainer is plastic. Insert the spring (12) into the retainer, followed by the valve (11) onto the spring. Finally, insert seat (10) with new O-ring into the valve bore with the larger I.D. chamfer (seating surface) facing down, towards the valve.
 - Outlet Valves (five outer, smaller valves). Insert the outlet seat (16) with new O-ring into the valve bore with the larger I.D. chamfer (seating surface) facing up. Insert a Tetra Seal (17) if valve spring retainers are plastic. Insert the valve (18) and spring (19) onto the seat. Finally, insert the spring retainer (20) into the valve bore.
 - Make sure the springs are all properly nested into the spring retainers to ensure proper valve performance.
- d. Inspect the diaphragm carefully. A damaged diaphragm generally indicates a pumping system problem and replacing only the diaphragm will not solve the larger problem. Inspect the diaphragm for the following:
 - **Small puncture.** Usually caused by a sharp foreign object in the fluid, or by an ice particle.
 - **Diaphragm pulled away** from the metal insert. Usually caused by excessive inlet vacuum, or by overpressurization of the pump inlet.
 - **Outer diaphragm bead extruded.** Usually caused by overpressurization of the pump or by extremely high temperatures.
 - **Diaphragm becoming stiff** and losing flexibility. Usually caused by pumping a fluid that is incompatible with the diaphragm material.
 - **Cut diaphragm convolute.** Usually caused by excessive inlet vacuum.

CAUTION: If a diaphragm has ruptured and foreign material or water has entered the oil reservoir, do not operate the pump. Check all diaphragms, then flush the reservoir completely (as outlined below) and refill it with fresh oil. Never let the pump stand with foreign material or water in the reservoir, or with the reservoir empty.
- e. Clean away any spilled oil.
- f. Install a good or new diaphragm and tighten to 10 in.-lbs (110 N-cm).
- g. Repeat the above inspection procedure (and replacement, if necessary) with the other four diaphragms.

3. Inspect and Replace Diaphragms (21)

- a. Lift a diaphragm by one edge, and turn the pump shaft until the diaphragm moves up to “top dead center”. This will expose machined cross-holes in the valve plunger (51) behind the diaphragm.
- b. Insert a 3/32 x 6 in. hex wrench through one of the machined cross-holes, to hold the diaphragm up and to keep the valve plunger from rotating. The proper size tool is included in the Wanner Tool Kit. (Don’t remove the tool until the new diaphragm is installed in step “f” below.)
- c. Unscrew the diaphragm. Use a 5/16-in. (8-mm) open-end wrench, and turn counterclockwise.

4. Flush Contaminant from Hydraulic End

(only if a diaphragm has ruptured)

- a. With the valve plate and manifold still removed (see above), remove the oil drain cap (26) allow all oil and contaminant to drain out.
- b. Fill the reservoir with kerosene or solvent, manually turn the pump shaft to circulate the kerosene, and drain. Dispose of this contaminated fluid properly.
- c. Repeat the flushing procedure (step “b” above).
- d. Fill the reservoir with fresh oil, manually turn the pump shaft to circulate the oil, and drain again.
- e. Refill the reservoir. If the oil appears milky, there is still contaminant in the reservoir. Repeat the flushing procedure until the oil appears clean.

D/G-17 Service (Fluid End)

5. Prime the Hydraulic Cells

- a. With the pump **horizontal and the fluid end head removed**, fill the reservoir with the appropriate Hydra oil for the application. Have a catch basin for oil that leaks from behind the diaphragms when priming. Catch the oil and dispose of it properly; **do not reuse it**.
- b. All air in the oil within the hydraulic cell (behind the diaphragm) must be forced out by turning the shaft (and thus pumping the piston). A Shaft Rotator is included in the Wanner D-15 Tool Kit. Rotate the shaft two revolutions and refill the reservoir. Rotate it two more revolutions and refill again. Continue to do this until the oil that is being pumped from the back of all five diaphragms is free of air.
- c. Wipe excess oil from the cylinder housing (23) and diaphragms (21).
- d. Ensure that the pump housing is completely full of oil.
- e. Replace oil fill cap (28).

6. Reinstall Valve Plate (24) and Manifold (4)

- a. Reinstall the valve plate (24), with the valve assemblies installed as outlined above, onto the cylinder housing center spud and alignment pin (8).
- b. Install capscrew (22) with flat washer (3) through center hole in valve plate and torque to 45 ft-lbs (60 N-m).
- c. Install new O-rings (5, 6, 7) into the grooves in the front side of the valve plate. Use grease or petroleum jelly to hold them in place.
- d. Reinstall the manifold (4) over alignment pin (8), engaging the center spud of the manifold into the center of the valve plate.
- e. Install capscrews (1) with flat washers (3) through the five center holes in the manifold. Thread each capscrew in several turns, but do not torque yet.
- f. Install capscrews (2) with flat washers (3) through the twelve outer holes at the perimeter of the manifold. Thread each capscrew in several turns, but do not torque yet.
- g. Return to the five capscrews at the center of the manifold and alternately tighten opposite bolts until all are secure. Torque to 45 ft-lbs (60 N-m).
- h. Return to the twelve capscrews at the perimeter of the manifold and alternately tighten opposite bolts until all are secure. Torque to 45 ft-lbs (60 N-m).
- i. Recheck all capscrews for tightness and proper torque, starting with the five at the center of the manifold, then the twelve at the perimeter.

D/G-17 Service (Hydraulic End)

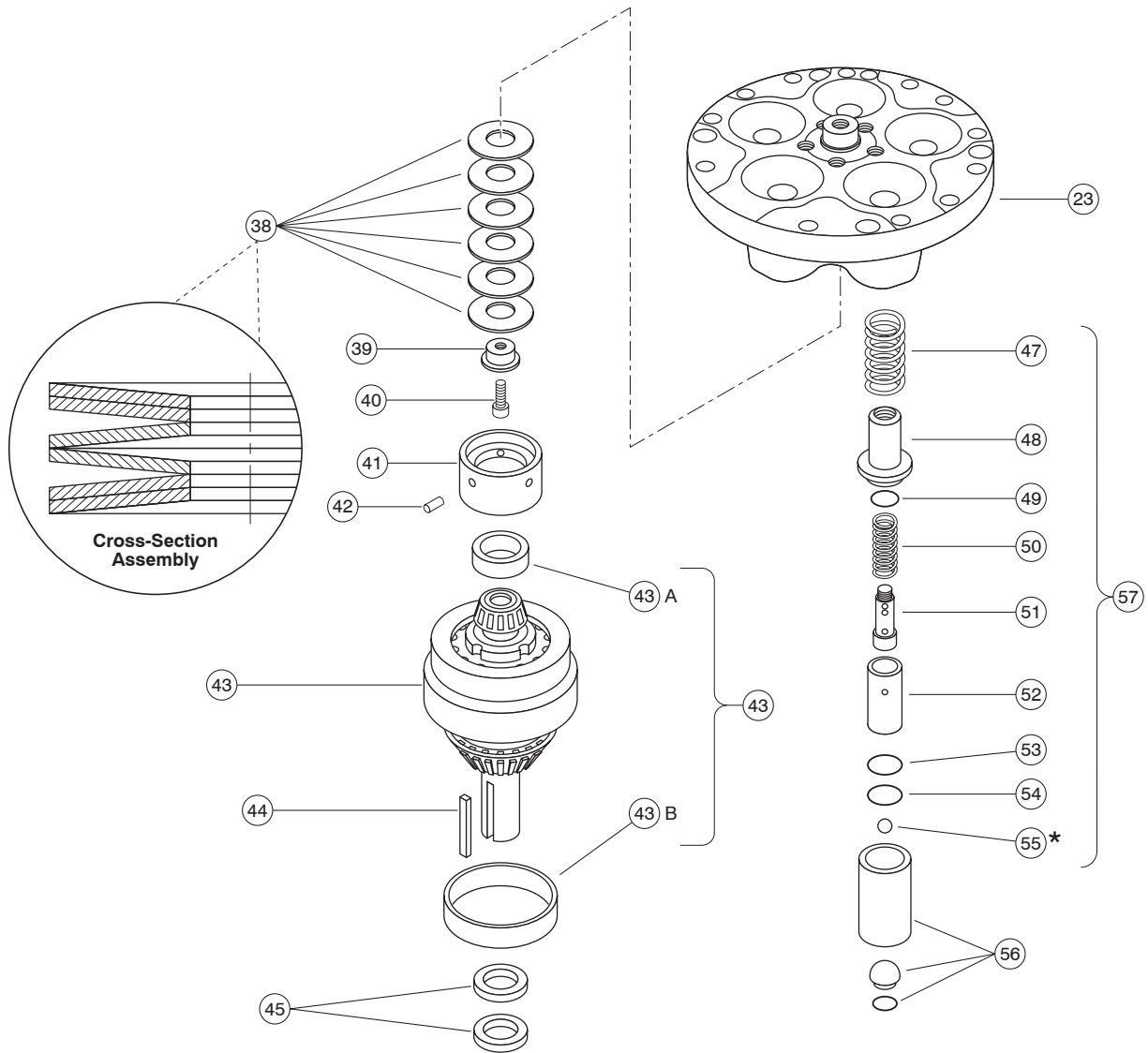

* Qty per piston: 4

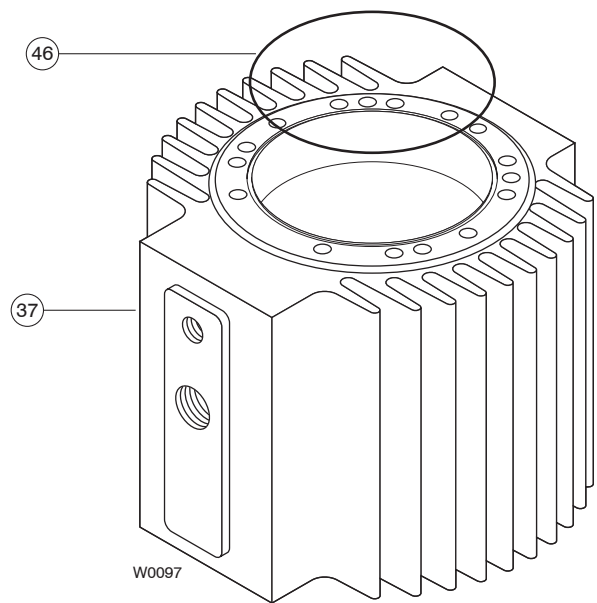

W0097

Bolt Torque Specifications

Ref. #	Assembly Torque
40	15 ft-lbs (20 N-m)

D/G-17 Service (Hydraulic End)

NOTE: The numbers in parentheses are the Ref. Nos. on the illustrations in the Parts Manual.

This section explains how to disassemble and inspect the hydraulic end (oil reservoir) of the pump.

CAUTION: Do not disassemble the hydraulic end unless you are a skilled mechanic. For assistance, contact Wanner Engineering (612-332-5681) or the distributor in your area.

CAUTION: The four socket-head capscrews (29) that screw through the cylinder housing (23) into the pump housing hold these parts together. Do not remove these four screws except when repairing the hydraulic end.

NOTE: The following service procedures refer several times to the Wanner D-15 Tool Kit. We strongly urge you **not to repair** the hydraulic end of the pump without using the tools in this Kit (available from Wanner Engineering or your local distributor). Refer also to the list of tools and supplies in the Fluid-End Service Section.

Service Procedure

NOTE: Before Step 1 Remove Pump Housing, scribe a line on the perimeter of the cylinder housing and onto the pump housing. This will simplify alignment during reassembly.

1. Remove Pump Housing

- Remove the manifold and valve plate, and the diaphragms, from the pump. Refer to the Fluid-End Service Section
- Drain the oil from the pump housing by removing plug (33), then tipping the pump up onto the cylinder housing (23). Remove oil reservoir (39), clean and set aside. Return the pump to its secure horizontal position. Dispose of the oil properly.
- Check the shaft for sharp burrs. Smooth any burrs, to prevent scarring the seals (45) when removing the shaft.
- Reinsert two perimeter bolts (2) through the cylinder housing (23) into the pump housing (37), at the 10 and 2 o'clock positions, to support the parts as the pump is being disassembled.
- Remove the four socket-head capscrews (29) loosening alternately so the cylinder housing separates evenly from the pump housing. Slide the cylinder housing out on the two bolts (2) that were inserted for support in Step d above. The preload on the piston return springs will push the cylinder housing out of the pump housing. Remove the support bolts and cylinder housing assembly.
NOTE: the piston assemblies will be free to slide out of the cylinder housing, so keep the cylinder housing orientated with pistons up, for later disassembly.
- Remove the shaft assembly (43) sliding the shaft out of the seals (45). The parts are heavy.
- Remove the bearing adjustment plate (41) and inspect the bearing cup (43A). Inspect all parts for wear, and replace if necessary.

- Inspect the cam and bearings (43), and the bearing cup (43B) in the housing. If the bearings are pitted or binding, or if the bearing cup in the housing is worn, contact Wanner Engineering.

CAUTION: If a bearing cup or bearing cone is replaced, they must be replaced as a pair or premature failure will result.

2. Disassemble Pistons

Inspect and clean all parts of the hydraulic piston assemblies (57). Replace all O-rings and any other parts that are worn or damaged.

3. Reassemble Pistons

- Drop a ball (55) into each opening in the bottom of the piston assembly (56).
NOTE: Using grease on the O-rings, and lubricating the parts, will aid in assembly.
- Insert a retaining washer (54) and O-ring (53) to hold the balls in place.
- Insert a valve plunger (51) into the valve cylinder (52). Slide a spring (50) over the valve plunger (51), inside the valve cylinder (52).
- Insert an O-ring (49) into the spring retainer (48).
- Slide the assembled valve cylinder (52), valve plunger (51), and spring (50) into the spring retainer (48).
- Slide the complete cylinder-and-retainer assembly into the piston assembly.
- Insert a piston return spring (47) into the piston assembly, with the larger end going into the piston first. This is a tight fit, and can best be done by "screwing" the spring in counterclockwise.
- Repeat the above procedure for the other four pistons.

4. Remove Shaft Seals (45)

Inspect the shaft seals (45) before continuing. If they look damaged in any way, replace them. Remove by pounding them out from inside the pump housing. Replace both shaft seals at the same time. Clean the bore in the housing using emery cloth or Scotch-Brite™.

5. Reassemble Pump Housing (37), Cam Assembly (43), and Cylinder Housing (23)

- With the pump housing vertical and the baseplate removed, set it with the open end up on a workbench. Grease the groove at the face of the housing and install O-ring (46). Set aside.

D/G-17 Service (Hydraulic End)

- b. Set the cylinder housing, with the diaphragm pockets facing down, onto smooth, clean, 4" high blocks. Insert the bearing adjustment plate (41), with the bearing cup (43A) and dowel pin (42) into the cylinder housing. The dowel pin engages into the largest of the five slots in the cylinder housing.
- c. Insert the five piston assemblies into the cylinder housing.
- d. Set the cam assembly onto the cylinder housing sub-assembly such that the piston feet support the cam assembly and the nose bearing is centered over bearing cup (43A). Note: the cam assembly will be able to move from side to side slightly, as the nose bearing is not fully engaged into the bearing cup.
- e. If the shaft seals (45) are still in the pump housing, slide the seal protector (from the D-15 Tool Kit) over the shaft. Pick up the pump housing, lining up the marks made earlier on it and the cylinder housing. Slowly lower the pump housing over the shaft until the bearing cup (43B) rests on the upper bearing of the cam assembly.
- f. Start the four capscrews (29) by hand, using the 6 mm hex Allen wrench from the Wanner D-15 Tool Kit. Thread them through the counter bored holes in the cylinder housing, engaging the threads into the pump housing. Two full turns of each screw should be able to be achieved before noticeable resistance is met from the piston return springs. If this cannot be done remove the pump housing and check alignment of the cam assembly to the cylinder housing subassembly.
- g. Lift the pump assembly off the 4" blocks and set it onto the workbench. Position the baseplate (30) and gasket (38) onto the blocks so the cylinder housing and pin (8) can pass through the baseplate cutout. Set the pump assembly onto the gasket so the edge of the fins rest on the gasket. Using cap screws (32) and lockwashers (31), apply threadlocker (e.g. Loctite 242) to the threads of the capscrews and torque to 45 ft-lbs (60 N-m).
- h. Lift the pump assembly off of the 4" blocks and set it onto the workbench. Tip the pump assembly so it sits upright on the baseplate.

Return to the four cylinder housing capscrews (29) and tighten them to establish and maintain an even gap between the cylinder housing and pump housing. This will draw the cylinder housing into the pump housing, compressing the five piston return springs and the six disk springs that pre-load the cam assembly. Note: there is very minimal clearance between the cylinder housing pilot diameter and the main pump housing bore, so it is very important to alternately tighten the four capscrews, until the housings are flush together. The last 1/8" (3mm) requires more force to bring the housings together as all of the springs are nearing their maximum compression. Torque all four capscrews to 15 ft-lbs (20 N-m). Remove the shaft seal protector.

6. Install Shaft Seals (45)

- a. Apply a thin film of grease on the seal protector tool (included in the Wanner D-15 Tool Kit). Slide both seals onto the tool, with the spring side of the seals toward the open end of the tool. Apply a heavier coat of grease between the seals and press them together.
- b. Apply an anaerobic seal sealant or bearing retaining compound (e.g. Loctite 601 or 609) to the outside diameter of the seals.
- c. Apply a light film of grease to the pump shaft and slide the seal protector (with seals) over the shaft.
- d. Slide the seal inserter tool (included in the Wanner D-15 Tool Kit) over the seal protector tool, and press the seals completely into place. Tap the tool with a soft mallet to firmly seat the seals flush to the pump housing.

7. Reinstall Diaphragms (21)

- a. Screw the plunger guide lifter (from the Wanner Tool Kit or Repair Kit) into the valve plunger (51). Pull out to expose the cross holes in the plunger. Rotate the shaft until the piston is at top dead center.
- b. Insert the 3/32-in. T-handle hex wrench (from the Wanner Tool Kit), through the plunger hole — to hold the plunger away from the cylinder housing (23), and to keep the plunger from turning when the diaphragm is being installed.
- c. Engage the diaphragm insert threads to the plunger threads, and turn the diaphragm by hand until the insert hits the shoulder of the valve plunger (51).
- d. Hold the T-handle hex wrench to secure the valve plunger, and torque the diaphragm insert to 10 in.-lbs (110 N-cm) using a 5/16-in. (8-mm) open-end wrench.
- e. Repeat the above procedure for the plungers and diaphragms of the other four cylinders.
- f. Fill the reservoir with fresh oil and prime the pump, as outlined in the Fluid-End Service Section.

8. Reassemble Pump

Reassemble the pump as outlined in the Fluid-End Service Section.

D/G-17 Troubleshooting

Cavitation

- Inadequate fluid supply because:
 - Inlet line collapsed or clogged
 - Clogged line strainer
 - Inlet line too small or too long
 - Air leak in inlet line
 - Worn or damaged inlet hose
 - Suction line too long
 - Too many valves and elbows in inlet line
- Fluid too hot for inlet suction piping system.
- Air entrained in fluid piping system.
- Aeration and turbulence in supply tank.
- Inlet vacuum too high (refer to Installation, Inlet piping).

Symptoms of Cavitation

- Excessive pump valve noise
- Premature failure of spring or retainer
- Volume or pressure drop
- Rough-running pump
- Premature failure of diaphragms

Drop in Volume or Pressure

A drop in volume or pressure can be caused by one or more of the following:

- Air leak in suction piping
- Clogged suction line or suction strainer
- Suction line inlet above fluid level in tank
- Inadequate fluid supply
- Pump not operating at proper RPM
- Relief valve bypassing fluid
- Worn pump valve parts
- Foreign material in inlet or outlet valves
- Loss of oil prime in cells because of low oil level
- Ruptured diaphragm
- Cavitation
- Warped manifold from overpressurized system
- O-rings forced out of their grooves from overpressurization
- Air leak in suction line strainer or gasket
- Cracked suction hose.
- Empty supply tank
- Excessive aeration and turbulence in supply tank
- Abrasives in the fluid
- Valve incompatible with corrosives in the fluid
- Pump running too fast
- Worn and slipping drive belt(s)
- Worn spray nozzle(s)

Pump Runs Rough

- Worn pump valves
- Air lock in outlet system
- Oil level low
- Wrong weight of oil for cold operating temperatures (change to lighter weight)
- Cavitation
- Air in suction line
- Restriction in inlet/suction line
- Hydraulic cells not primed after changing diaphragm
- Foreign material in inlet or outlet valve
- Damaged diaphragm
- Fatigued or broken valve spring

Premature Failure of Diaphragm

- Frozen pump
- Puncture by a foreign object
- Elastomer incompatible with fluid being pumped
- Pump running too fast
- Excess pressure
- Cavitation

Water (or Process Fluid) in Oil Reservoir

- Condensation
- Ruptured diaphragm
- Hydraulic cell not properly primed after diaphragm replacement
- Frozen pump

Water (or Process Fluid) Pulsations

NOTE: Small pulsations are normal in single-acting pumps with multiple pumping chambers.

- Foreign object lodged in pump valve
- Loss of prime in hydraulic cell because of low oil level
- Air in suction line
- Valve spring (12, 19) broken
- Cavitation
- Aeration or turbulence in supply tank

D/G-17 Troubleshooting

Valve Wear

- Normal wear from high-speed operation
- Cavitation
- Abrasives in the fluid
- Valve incompatible with corrosives in the fluid
- Pump running too fast

Loss of Oil

- External seepage
- Rupture of diaphragm
- Frozen pump
- Worn shaft seal
- Oil drain piping or fill cap loose.
- Valve plate and manifold bolts loose
- Pump housing porosity

Premature Failure of Valve Spring or Retainer

- Cavitation
- Foreign object in the pump
- Pump running too fast
- Spring/retainer material incompatible with fluid being pumped
- Excessive inlet pressure.

Limited Warranty

Wanner Engineering, Inc. extends to the original purchaser of equipment manufactured by it and bearing its name, a limited one-year warranty from the date of purchase against defects in material or workmanship, provided that the equipment is installed and operated in accordance with the recommendations and instructions of Wanner Engineering, Inc. Wanner Engineering, Inc. will repair or replace, at its option, defective parts without charge if such parts are returned with transportation charges prepaid to Wanner Engineering, Inc., 1204 Chestnut Avenue, Minneapolis, Minnesota 55403.

This warranty does not cover:

1. The electric motors (if any), which are covered by the separate warranties of the manufacturers of these components.
2. Normal wear and/or damage caused by or related to abrasion, corrosion, abuse, negligence, accident, faulty installation or tampering in a manner which impairs normal operation.
3. Transportation costs.

This limited warranty is exclusive, and is in lieu of any other warranties (express or implied) including warranty of merchantability or warranty of fitness for a particular purpose and of any non contractual liabilities including product liabilities based on negligence or strict liability. Every form of liability for direct, special, incidental or consequential damages or loss is expressly excluded and denied.



WANNER ENGINEERING, INC.

1204 Chestnut Avenue, Minneapolis, MN 55403
TEL: (612) 332-5681 FAX: (612) 332-6937
TOLL-FREE FAX [US only]: (800) 332-6812

www.hydra-cell.com
email: sales@wannereng.com

© 2004 Wanner Engineering, Inc. Printed in USA
D17-991-2400A 5/2004, Revised 2/2007