

D-17 (NEMA)
G-17 (IEC Face)

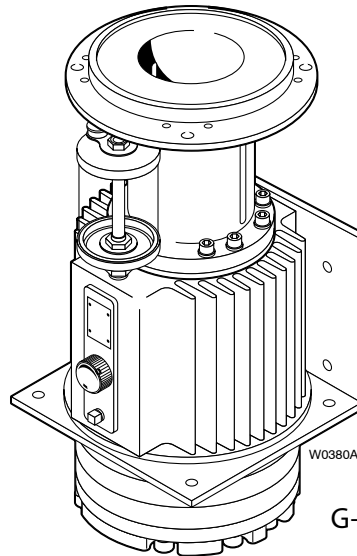

G-17 (IEC Flange)

Part Number	Pump/Motor Adapter Kit Description
A04-041-1200	D-17 Kit for NEMA 182/184TC, 254/256TC C-Face Motors

A04-041-1202 D-17 Kit for NEMA 284/286TC C-Face Motors

Dimensions

inches (mm)

NEMA Adapters: A04-041-1200; A04-041-1202

IEC Adapter: A04-041-1203

Part Number	Pump/Motor Adapter Kit Description
A04-041-1203	G-17 Kit for IEC 160 B14 Face Motors

A04-041-1201 G-17 Kit for IEC 132 B5 Flange Motors

A04-041-1205 G-17 Kit for IEC 160/180 B5 Flange Motors

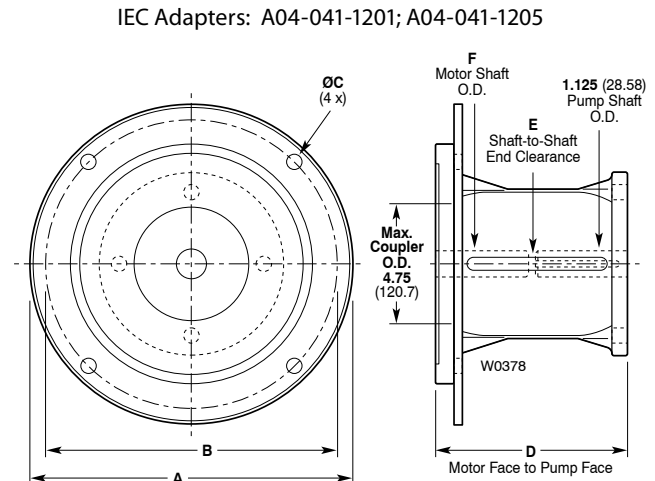
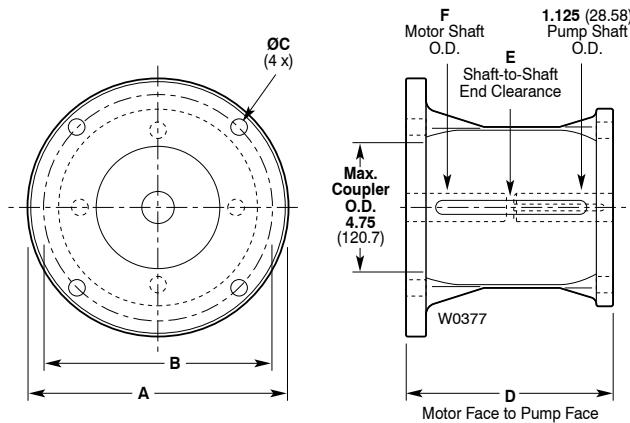

IEC Adapters: A04-041-1201; A04-041-1205

Dimensions in (mm)

Kit Part Number	Adapter Kit Motor Size	A	B	C	D	E	F
A04-041-1200	NEMA 182/184TC	8.75	7.25	0.54	8.0	1.71	1.125
	NEMA 213/215TC	8.75	7.25	0.54	8.0	0.96	1.375
	NEMA 254/256TC	8.75	7.25	0.54	8.0	0.33	1.625
A04-041-1202	NEMA 284/286TC	10.75	9.00	0.54	8.4	0.14	1.875
A04-041-1203	IEC 160 B14 Face	(250)	(215)	(13.1)	(208.3)	(3.8)	(42)
A04-041-1201	IEC 132 B5 Flange	(328)	(265)	(13.1)	(203.2)	(27.7)	(38)
A04-041-1205	IEC 160/180 B5 Flange	(328)	(300)	(17.0)	(208.3)	(3.8)	(42/48)



WANNER ENGINEERING, INC.

Installation:

Attach coupling hubs (not included in Adapter Kit), to pump and motor shafts. Slide coupling sleeve onto motor shaft coupling hub.

On NEMA and IEC B14 Face models, attach adapter to motor using bolts (64) and lockwashers (65). IEC B5 Flange models use additional lockwashers (65), spacers (66), and nuts (67).

With coupling sleeve positioned on motor shaft hub, assemble pump onto motor adapter making sure to engage pilot ring of adapter to groove in pump housing.

Fasten pump to adapter using socket-head cap screws (62) with lockwashers (63).

Make any adjustments to the position of the coupling hubs through the access slots in the sides of the adapter. Tighten coupling set screws

NEMA Adapters: A04-041-1200; A04-041-1202
IEC Adapter: A04-041-1203

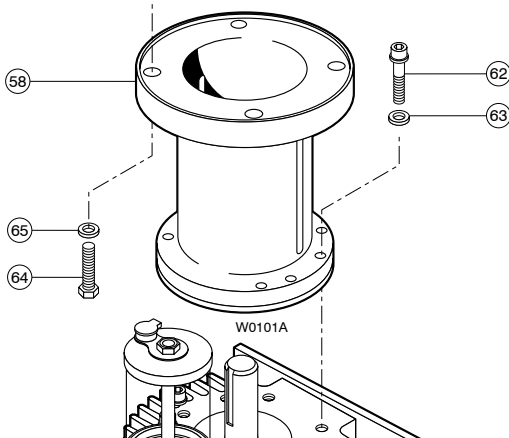

IEC Adapters: A04-041-1201; A04-041-1205

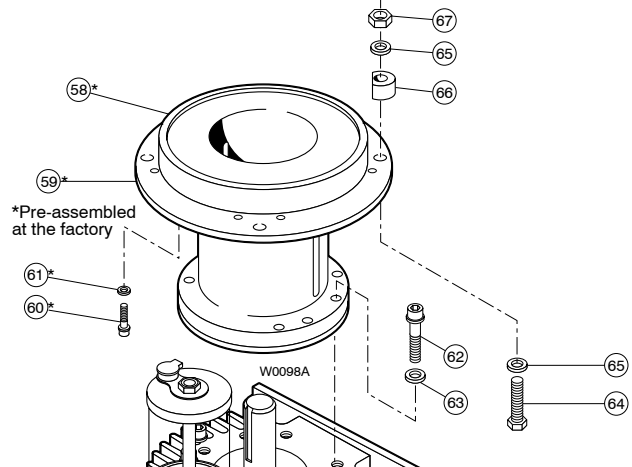

D Version (NEMA)

G Versions (IEC)

Ref No.	Description	D Version (NEMA)		G Versions (IEC)			Qty per Kit
		A04-041-1200 182/256TC Part Number	A04-041-1202 284/286TC Part Number	A04-041-1203 160 B14 Face Part Number	A04-041-1201 132 B5 Flange Part Number	A04-041-1205 160/180 B5 Part Number	
58	Pump/Motor Adapter	A04-041-1000	A04-041-1002	A04-041-1003	A04-041-1001	A04-041-1005	1
59	Clamping Ring	—	—	—	A04-120-1005	A04-120-1005	1
60	Cap Screw, socket-head	—	—	—	G03-029-2010 M6	G10-087-2010 M10	8
61	Lockwasher, split	—	—	—	D03-050-2010 1/4"	G25-048-2010 M10	8
62	Cap Screw, Socket-head, M10	G03-068-2010	G03-068-2010	G03-068-2010	G03-068-2010	G03-068-2010	8
63	Lockwasher, split, M10	G25-048-2010	G25-048-2010	G25-048-2010	G25-048-2010	G25-048-2010	8
64	Cap Screw, Hex-head, 1/2"	M10-110-2000	M10-110-2000	A04-043-2010 Soc.hd,M12	G40-101-2010 Soc.hd,M12	A04-046-2016 Soc.hd,M16	4
65	Lockwasher, split	M10-111-2000 1/2"	M10-111-2000 1/2"	M10-111-2000 1/2"	M10-111-2000* 1/2"	A04-044-2016* 5/8"	4
66	Spacer	—	—	—	A04-120-1011	A04-120-1015	4
67	Hex Nut	—	—	—	A04-045-2010	A04-045-2016	4

*Quantity/Kit = 8



WANNER ENGINEERING, INC.

1204 Chestnut Avenue, Minneapolis, MN 55403

TEL: (612) 332-5681 FAX: (612) 332-6937

TOLL-FREE FAX [US only]: (800) 332-6812

www.hydra-cell.com email:sales@wannereng.com

© 2004 Wanner Engineering, Inc. Printed in USA
D17-991-2403A 5/2004, Revised 2/2007